



**DE** Entlastungskit

**EN** Strain relief kit

**FR** Kit de délestage

**ES** Kit de descarga

**IT** Kit di alleggerimento

**NL** Ontlastingskit

**US** Relief kit

120 24 35 // Terra Rake 1600 / Terra Rake 2100 / Terra Float Air

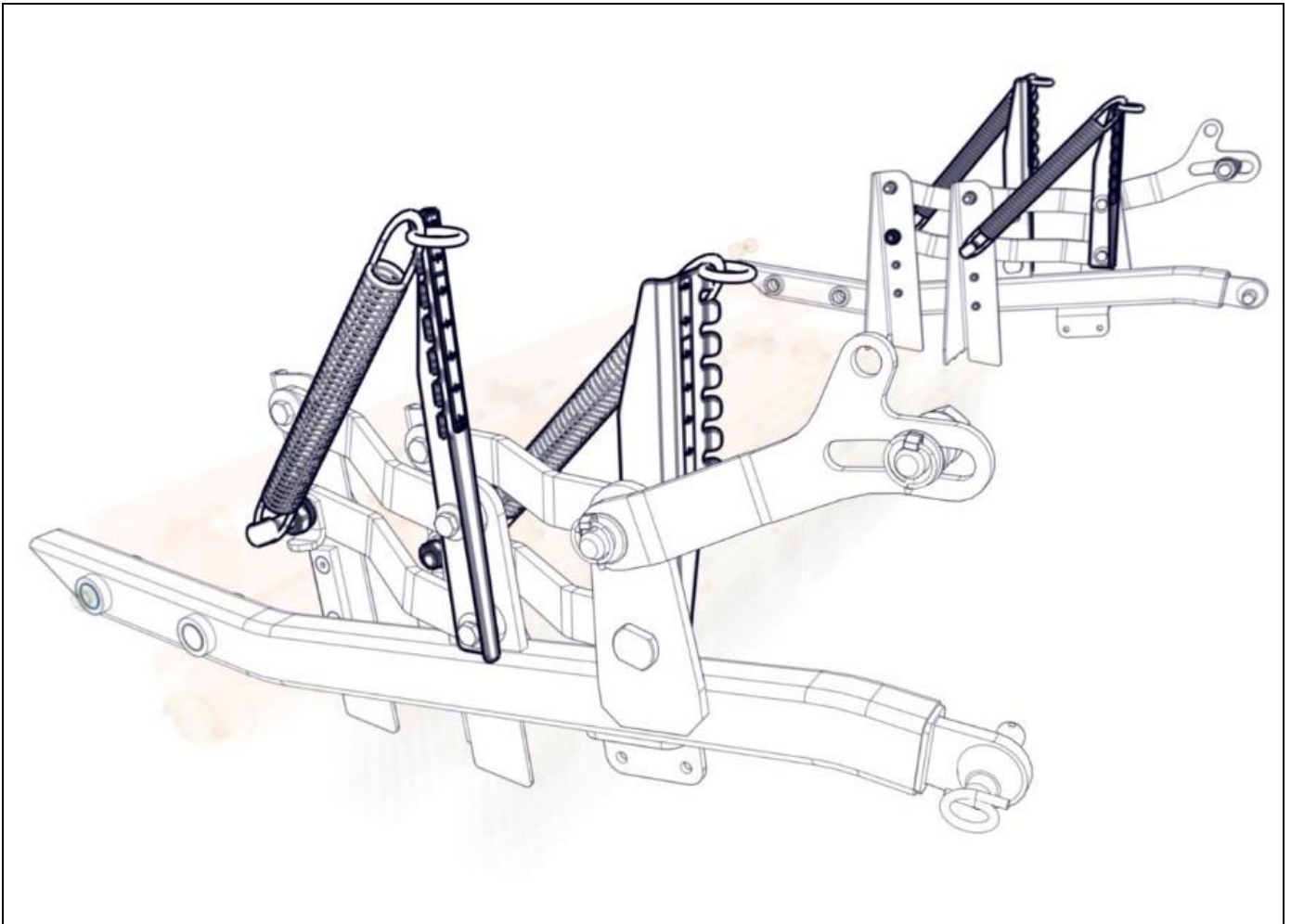

## Inhalt

<b>1. Übersicht – Stückliste</b> .....	<b>4</b>
<b>2. DE</b> .....	<b>5</b>
2.1. Vorwort .....	5
2.1.1 Terra Rake .....	5
2.1.2 Terra Float Air .....	5
2.2. Entlastungskit montieren .....	5
2.3. Entlastungskit einstellen .....	7
2.3.1 Einstellung für Kunstrasenflächen .....	8
2.3.2 Einstellung Rasenflächen .....	8
<b>3. EN</b> .....	<b>8</b>
3.1. Preface .....	8
3.1.1 Terra Rake .....	8
3.1.2 Terra Float Air .....	9
3.2. Mounting the strain relief kit .....	9
3.3. Setting the strain relief kit .....	11
3.3.1 Setting for synthetic turf .....	11
3.3.2 Setting for lawns .....	12
<b>4. FR</b> .....	<b>12</b>
4.1. Préface .....	12
4.1.1 Terra Rake .....	12
4.1.2 Terra Float Air .....	12
4.2. Montage el kit de délestage .....	13
4.3. Réglage du kit de délestage .....	15
4.3.1 Réglage pour les gazons artificiels .....	15
4.4. Réglage pour les gazons .....	15
<b>5. ES</b> .....	<b>16</b>
5.1. A modo de introducccion .....	16
5.1.1 Terra Rake .....	16
5.1.2 Terra Float Air .....	16
5.2. Montar el kit de descarga .....	17
5.3. Ajustar el kit de descarga .....	19
5.3.1 Ajuste para superficies de hierba artificial .....	19
5.3.2 Ajuste para superficies de césped .....	19
<b>6. IT</b> .....	<b>20</b>
6.1. Prefazione .....	20
6.1.1 Terra Rake .....	20
6.1.2 Terra Float Air .....	20
6.2. Montaggio del kit di alleggrimento .....	20

6.3.	Regolazione del kit di alleggerimento .....	23
6.3.1	Regolazione per i prati artificiali.....	23
6.3.2	Regolazione per prati .....	23
<b>7.</b>	<b>NL .....</b>	<b>24</b>
7.1.	Voorwoord .....	24
7.1.1	Terra Rake .....	24
7.1.2	Terra Float Air .....	24
7.2.	Ontlastingskit monteren .....	24
7.3.	Ontlastingskit instellenn .....	27
7.3.1	Instelling voor kunstgras.....	27
7.3.2	Instelling voor gazon .....	27
<b>8.</b>	<b>US .....</b>	<b>28</b>
8.1.	Introduction.....	28
8.1.1	Introduction.....	28
8.1.2	Terra Float Air .....	28
8.2.	Mounting relief kit.....	28
8.3.	Adjusting relief kit.....	31
8.3.1	Adjustment for artificial turf.....	31
8.3.2	Adjustment für lawns .....	31



Wiedenmann GmbH  
Am Bahnhof  
89192 Rammingen  
DEUTSCHLAND

Tel. +49 7345 953-0  
Fax +49 7345 953-233  
info@wiedenmann.de  
[www.wiedenmann.com](http://www.wiedenmann.com)

## 1. Übersicht – Stückliste

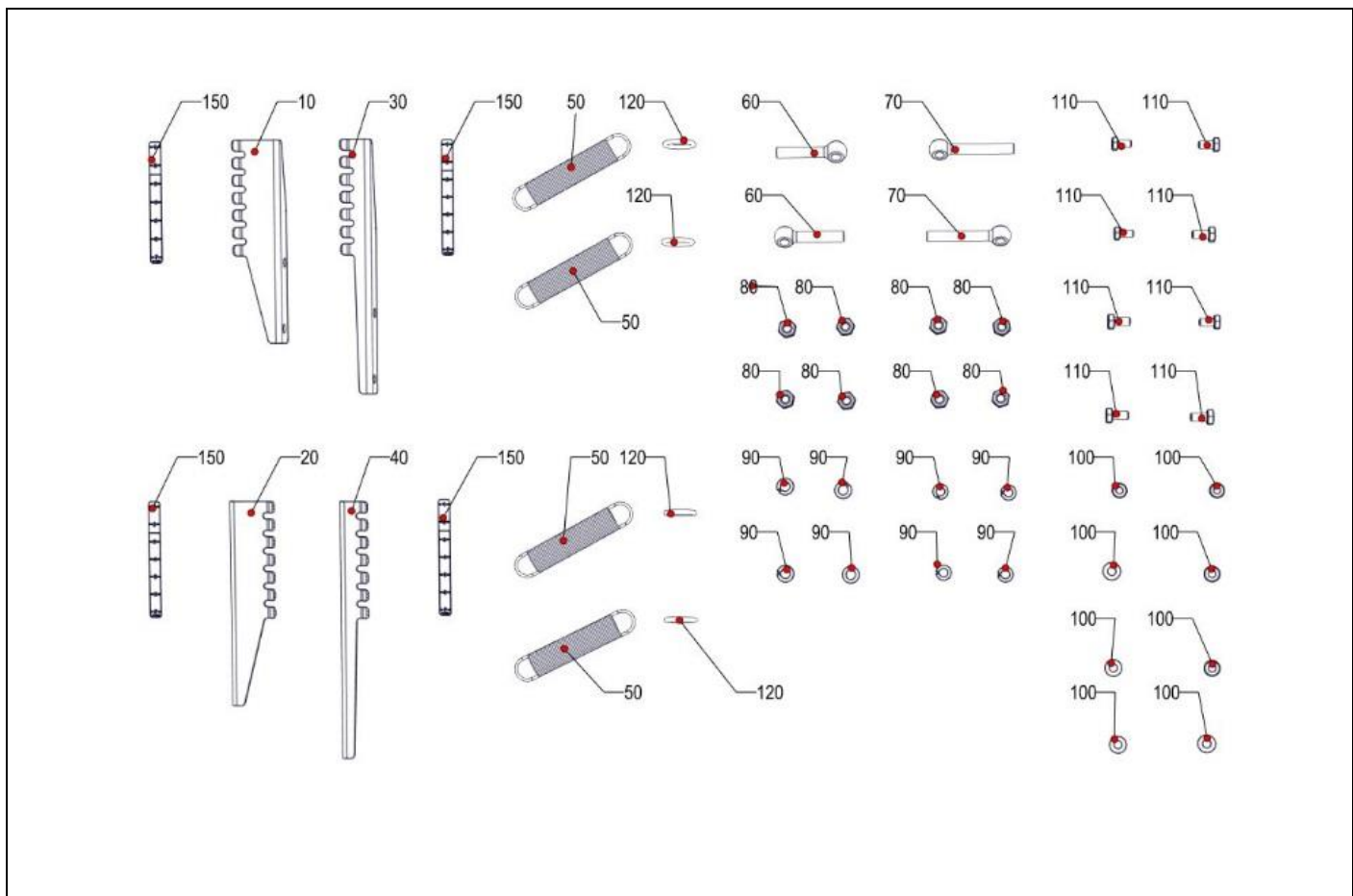

Pos. KEY Pos.	Art.-Nr. Part. No. No. d'art	Menge Quantity Quantité	Benennung Ø	Part name	Designation
10	120 24 40	1	Federhalter I links	Spring holder I left	Support à ressort I de gauche
20	120 24 41	1	Federhalter I rechts	Spring holder I right	Support à ressort I de droite
30	120 24 42	1	Federhalter II rechts	Spring holder II right	Support à ressort II de droite
40	120 24 43	1	Federhalter II links	Spring holder II left	Support à ressort II de gauche
50	101 47 64	4	Zugfeder	Tension spring	Ressort de traction
60	108 50 87	2	Augenschraube	Eye bolt	Vis à oeillet
70	101 08 86	2	Augenschraube	Eye bolt	Vis à oeillet
80	100 22 36	8	SKT-Mutter	Hexagonal nut	Écrou hexagonal
90	100 21 21	8	Federring	Lock washer	Rondelle ressort
100	100 20 24	8	U-Scheibe	Washer	Rondelle
110	101 47 67	8	SKT-Schraube	Hexagonal screw	Vis à tête hexagonale
120	101 47 67	4	Ring	Ring	Bague
150	103 85 62	4	Aufkleber Skala	Label-Scale	Autocollant-Cardan

## 2. DE

### 2.1. Vorwort

#### 2.1.1 Terra Rake

Dieses Gerät ist ausschließlich für die gewerbliche Nutzung und den üblichen Einsatz im ebenen Gelände in der Land- und Forstwirtschaft, Grünflächen- und Anlagenpflege zum Aufreißen und Aufräumen der Bodenoberfläche sowie zur Beseitigung von Rasenfz gebaut.

Zum erweiterten Einsatz auf Kunstrasenflächen um das Füllmaterial aufzulockern. Für den Einsatz auf Kunstrasenflächen muss die Sonderausrüstung „Entlastungskit“ angebaut sein („Bestimmungsgemäßer Gebrauch“).

#### 2.1.2 Terra Float Air

Dieses Gerät ist ausschließlich für die gewerbliche Nutzung und den üblichen Einsatz in der Grünflächen- und Anlagepflege gebaut, um auf nicht steinigen und ungefrorenen Böden eine umbruchlose Bestandsverbesserung von Golf Greens, Tees und anderen Sportrasen zu erhalten.

Die optionalen Nachsaateinheiten dienen ausschließlich zur Ausbringung von rieselfähigem Saatgut. Für den Einsatz auf Kunstrasenflächen muss die Sonderausrüstung „Entlastungskit“ angebaut sein („Bestimmungsgemäßer Gebrauch“).

### 2.2. Entlastungskit montieren



#### ⚠ ACHTUNG - GEFAHR!

- Zur Montage des Entlastungskit ist das Gerät auf einer ebenen Fläche abzustellen!

- Schrauben, Federring und U-Scheibe entfernen. Die abmontierte U-Scheibe wird ersetzt. (Auf beiden Seiten)

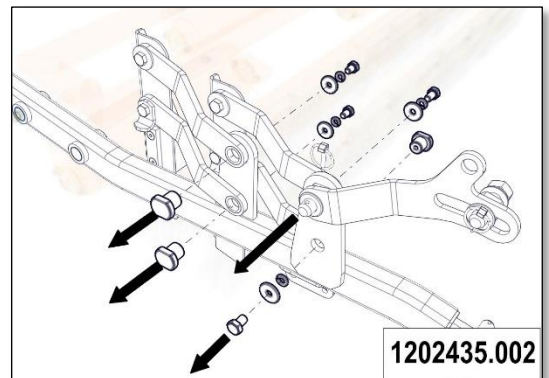

- Federhalter I (20) rechts mit U-Scheibe, Federring und Schraube wie in Bild 1202435.003 befestigen.

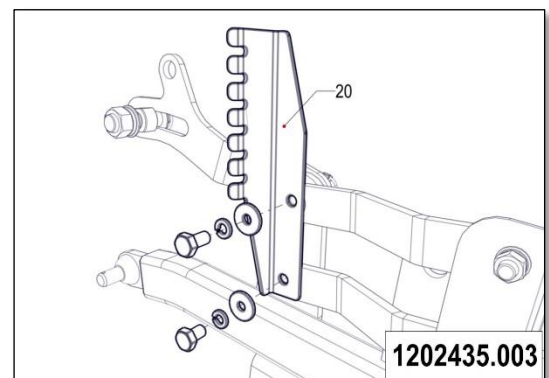

- Federhalter I (10) links mit U-Scheibe, Federring und Schraube wie in Bild 1202435.004 befestigen.

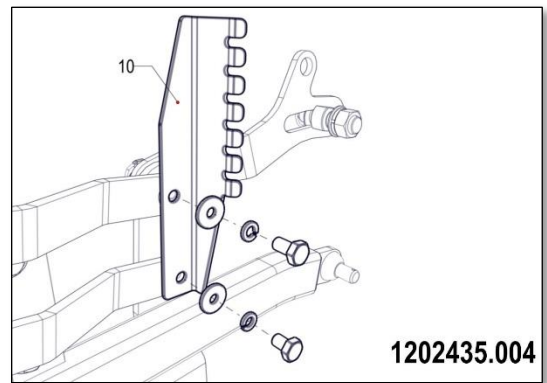

- Federhalter II (30) rechts mit U-Scheibe, Federring und Schraube wie in Bild 1202435.005 befestigen.

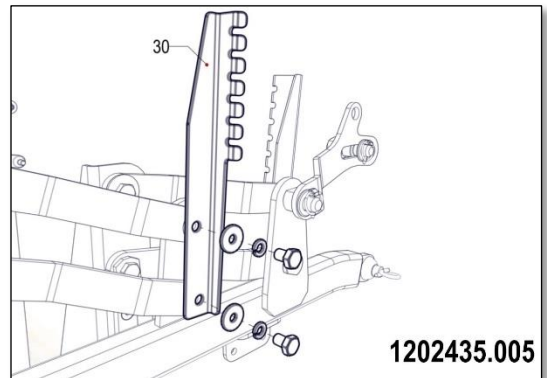

- Federhalter II (40) links mit U-Scheibe, Federring und Schraube wie in Bild 1202435.006 befestigen.

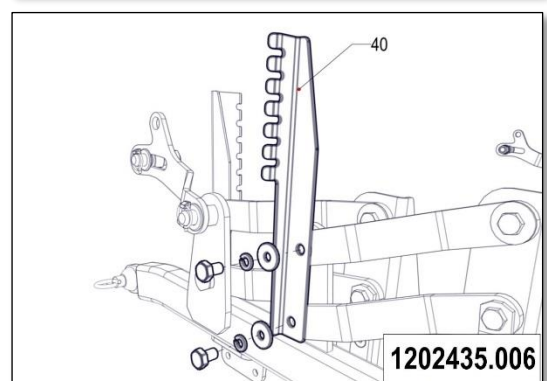

- Schraube, Federring und Mutter entfernen.

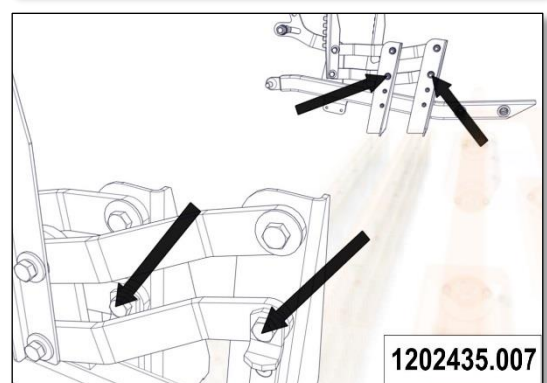

- Zugfeder (50) mit Augenschraube lang (70) von außen an Stelle der ausgebauten Schraube rechts mit U-Scheibe (100), Federring (90) und Mutter (80) befestigen.  
(Siehe Bild 1202435.008)

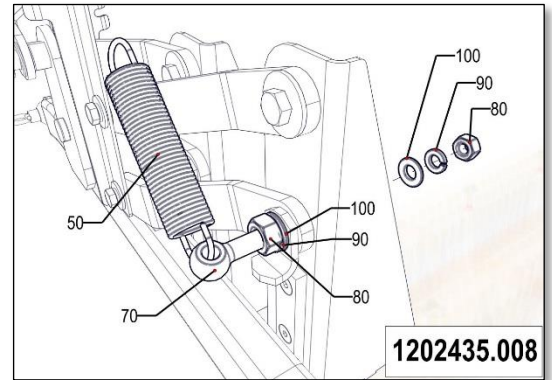

- Zugfeder (50) mit Augenschraube lang (70) von außen an Stelle der ausgebauten Schraube links mit U-Scheibe (100), Federring (90) und Mutter (80) befestigen.  
(Siehe Bild 1202435.009)

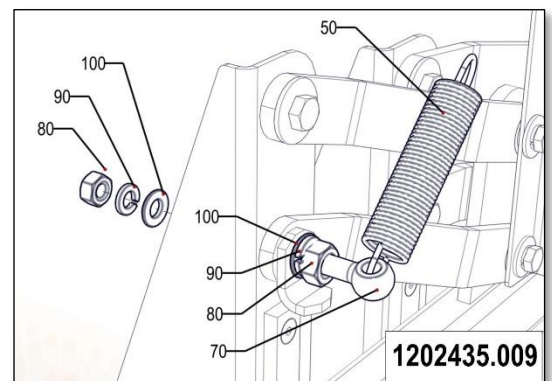

- Zugfeder (50) mit Augenschraube kurz (60) von innen an Stelle der ausgebauten Schraube rechts mit U-Scheibe (100), Federring (90) und Mutter (80) befestigen.  
(Siehe Bild 1202435.010)

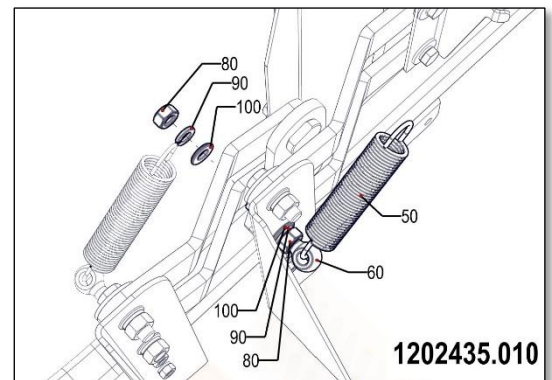

- Zugfeder (50) mit Augenschraube kurz (60) von innen an Stelle der ausgebauten Schraube links mit U-Scheibe (100), Federring (90) und Mutter (80) befestigen.  
(Siehe Bild 1202435.011)

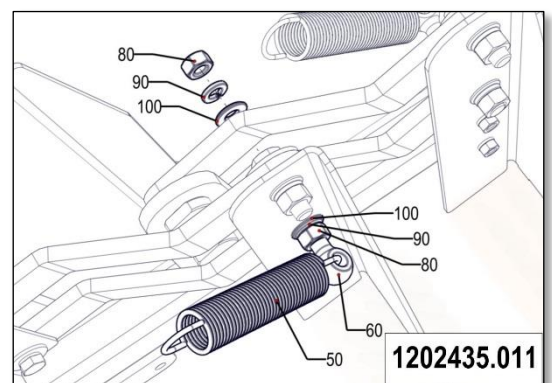

### 2.3. Entlastungskit einstellen

Der Entlastungskit reduziert die Eindringtiefe der Zinken auf die Kunstrasenfläche (Pflichtoption) oder auf empfindliche Rasenflächen (Option).

### 2.3.1 Einstellung für Kunstrasenflächen

Vor dem Einsatz auf Kunstrasenflächen muss der Entlastungskit montiert sein. Alle Zugfedern sind auf der Position 1 oder 2 eingehängt.

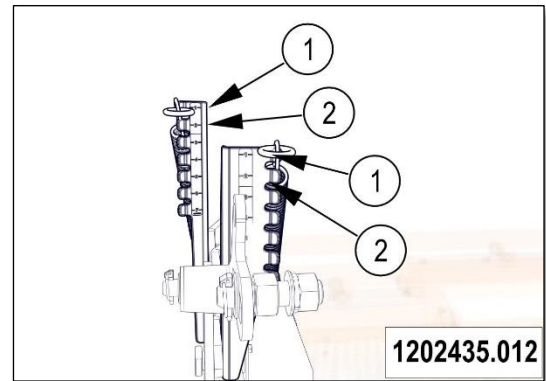

### 2.3.2 Einstellung Rasenflächen

Bei montiertem Entlastungskit sind alle Zugfedern auf den Positionen 3 bis 7 eingehängt.

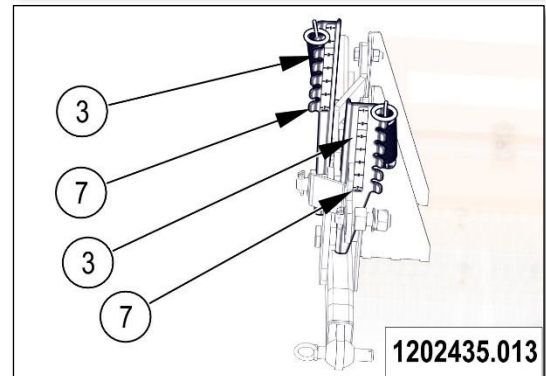

- Zugfedern (50) an der gewünschten Position einhängen.

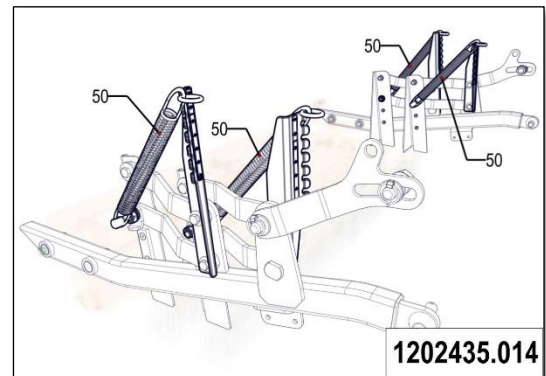

## 3. EN

### 3.1. Preface

#### 3.1.1 Terra Rake

This device is exclusively designed for commercial use as well as for use on even ground in agriculture, forestry, greens areas and ground maintenance for the digging and roughing up of the ground surface as well as the elimination of thatch.

It is also used on synthetic turf to loosen the filling material. The "strain relief kit" extra equipment must be mounted (i.e. mandatory) where the machine is used on synthetic turf ("Specified usw").



### 3.1.2 Terra Float Air

This device is exclusively designed for commercial use and use in green areas and grounds maintenance, to improve and maintain the condition of golfing greens, tees and other sports turf and create a smooth finish on ground that is not stony or frozen.

The optional reseeding units are used exclusively for spreading free-flowing seed. It is also used on synthetic turf to loosen the filling material. The "strain relief kit" extra equipment must be mounted (i.e. mandatory) where the machine is used on synthetic turf ("Specified usw").

### 3.2. Mounting the strain relief kit

	<b>⚠ ATTENTION - DANGER!</b>
➤ The machine shall be set down on an even, secure surface for the mounting of the strain relief kit!	

- Remove the screw, spring circlip and washer. The removed washer will be replaced. (On both sides.)

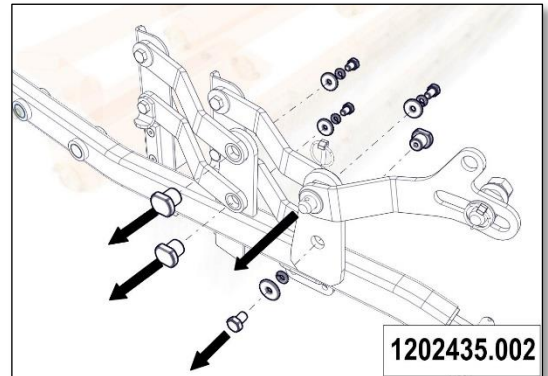

- Secure spring holder I (20) on right with washer, lock washer and screw as shown in figure 1202435.003.

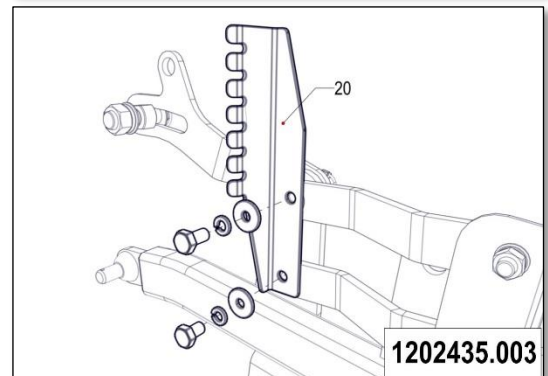

- Secure spring holder I (10) on left with washer, lock washer and screw as shown in figure 1202435.004.

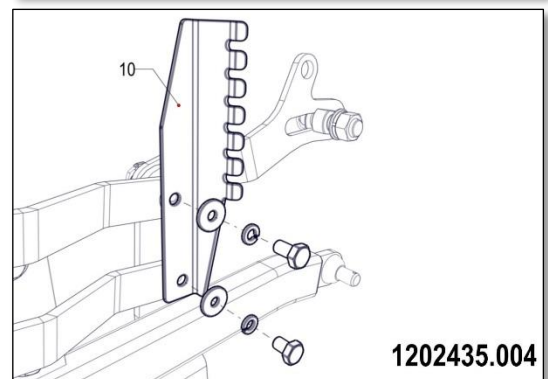

- Secure spring holder II (30) on right with washer, lock washer and screw as shown in figure 1202435.005.

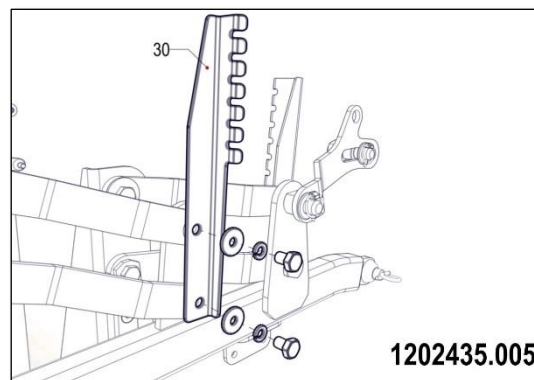

- Secure spring holder II (40) on left with washer, lock washer and screw as shown in figure 1202435.006.

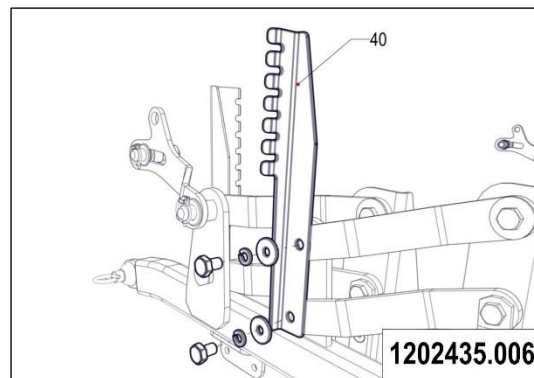

- Remove the screw, lock washer and nut.

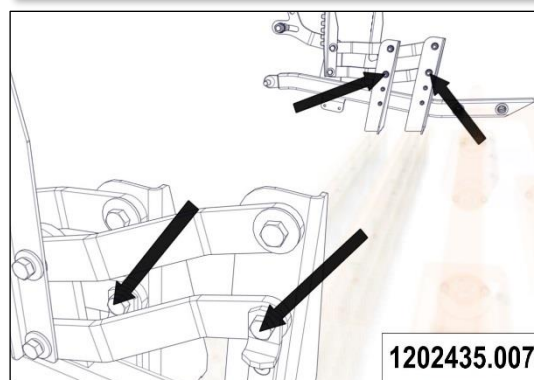

- Secure the tension spring (50) with long eye bolt (70) from the outside, instead of the removed screw on the right, with washer (100), lock washer (90) and hexagon nut (80). (see figure 1202435.008)

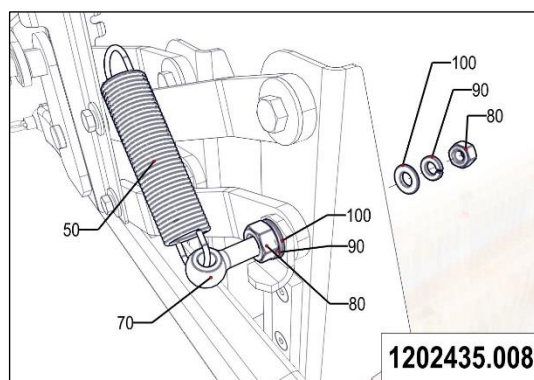

- Secure the tension spring (50) with long eye bolt (70) from the outside, instead of the removed screw on the left, with washer (100), lock washer (90) and hexagon nut (80). (see figure 1202435.009)

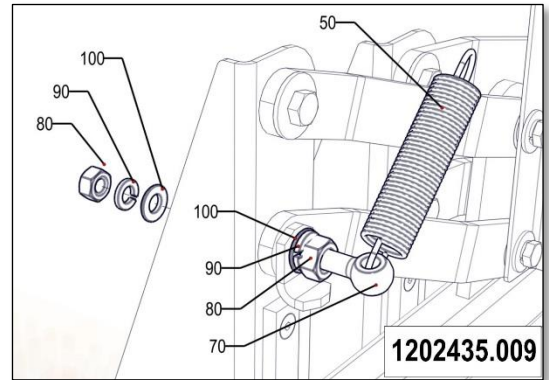

- Secure the tension spring (50) with long eye bolt (60) from the inside, instead of the removed screw on the right, with washer (100), lock washer (90) and hexagon nut (80). (see figure 1202435.010)

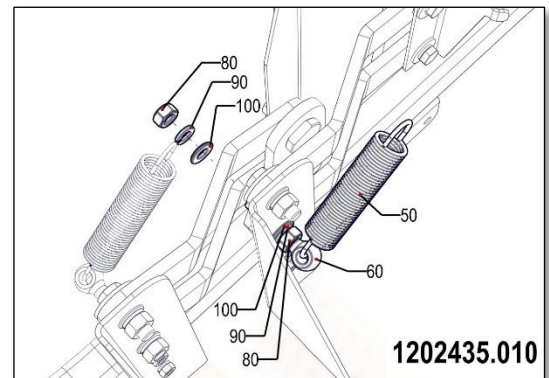

- Secure the tension spring (50) with long eye bolt (60) from the inside, instead of the removed screw on the left, with washer (100), lock washer (90) and hexagon nut (80). (see figure 1202435.011)

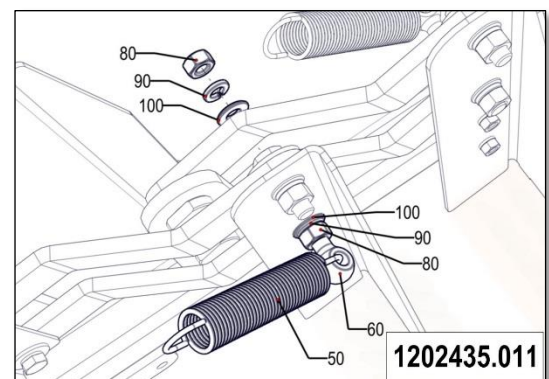

### 3.3. Setting the strain relief kit

The strain relief kit reduce the tine penetration depth in synthetic turf (mandatory) or sensitive lawns (option).

#### 3.3.1 Setting for synthetic turf

The strain relief kit must be mounted (i.e. mandatory) before the machine is used on synthetic turf.

All tension springs are fitted at position 1 or 2.

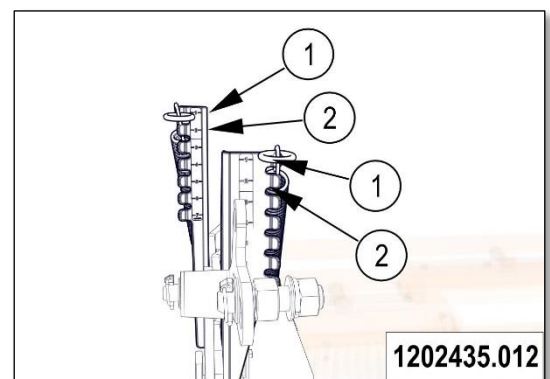

### 3.3.2 Setting for lawns

All tension springs are fitted at positions 3 to 7 in the case of mounted strain relief.

- Fit tension springs (50) at the desired position on the spring holders.

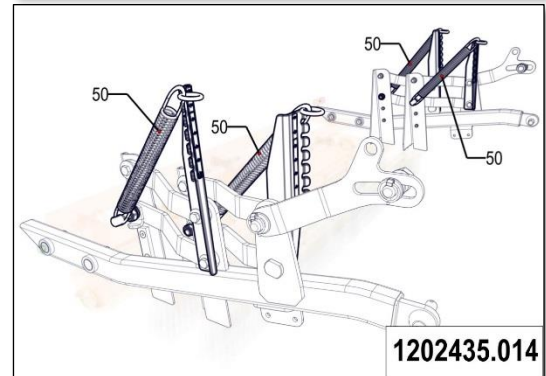
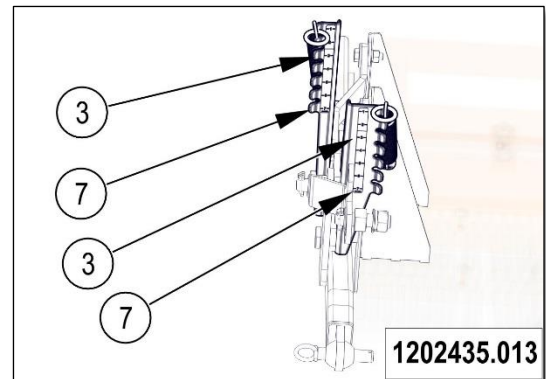

## 4. FR

### 4.1. Préface

#### 4.1.1 Terra Rake

Cet appareil est exclusivement pour l'exploitation normale en terrain plat en agriculture e sylviculture, pour l'entretien des espaces verts et des parcs, pour scarifier et gratter la surface du sol, ainsi que éliminer la mousse.

Pour une utilisation élargie sur les gazons artificiels afin d'ameublir et d'aérer le matériaux. L'équipement special "kit de délestage" doit être mis en place pour l'utilisation sur les gazons artificiels ("Utilisation conforme")

#### 4.1.2 Terra Float Air

Cet appareil est exclusivement destiné à une exploitation commerciale et ordinaire pour l'entretien des espaces verts et des parcs sur des sols non pierreux et non gelés afin d'améliorer la terre de terrains de golf, d'aires de départ et autres pelouses de sport sans la retourner.

Les unités de réensemencement en option servent exclusivement à appliquer de la semence ayant une capacité d'écoulement. Pour une utilisation élargie sur les gazons artificiels afin d'ameublir et d'aérer le matériaux. L'équipement special "kit de délestage" doit être mis en place pour l'utilisation sur les gazons artificiels ("Utilisation conforme").

## 4.2. Montage el kit de délestage



### ATTENTION - DANGER!

- Pour le montage du kit de délestage, positionner l'outil sur une surface plane et dure!

- Enlever la vis, la rondelle élastique bombée et la rondelle en U. La rondelle en U déposée sera remplacée (Des deux côtés.)

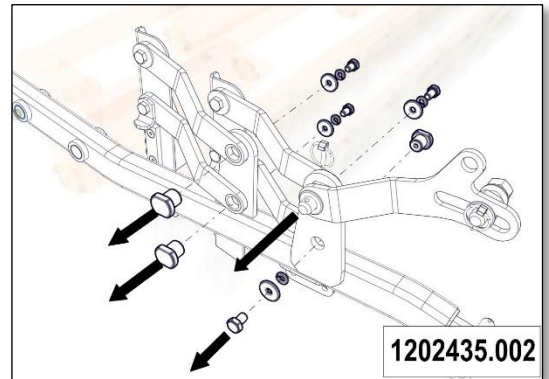

- Fixer le support de ressort I (20) à droite avec la rondelle en U, la rondelle élastique bombée et la vis, comme illustré sur la figure 1202435.003.

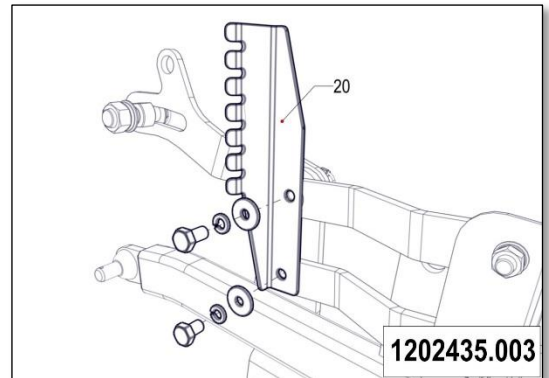

- Fixer le support de ressort I (10) à gauche avec la rondelle en U, la rondelle élastique bombée et la vis, comme illustré sur la figure 1202435.004.

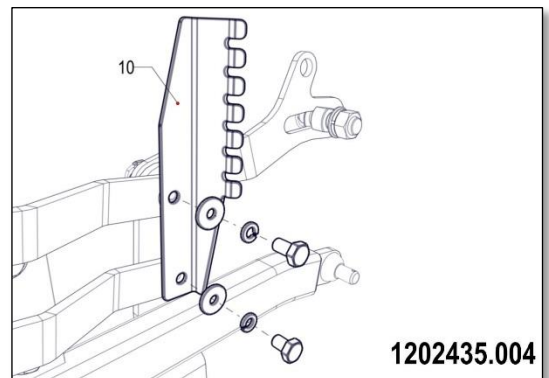

- Fixer le support de ressort II (30) à droite avec la rondelle en U, la rondelle élastique bombée et la vis, comme illustré sur la figure 1202435.005.

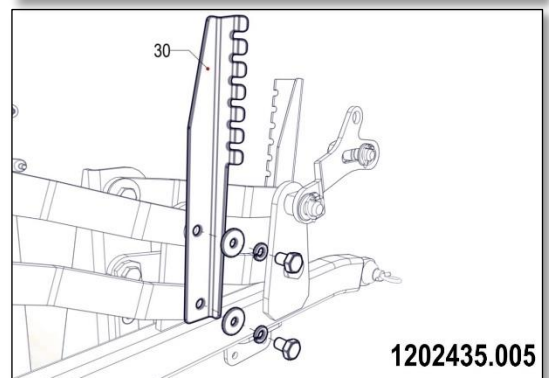

- Fixer le support de ressort II (40) à gauche avec la rondelle en U, la rondelle élastique bombée et la vis, comme illustré sur la figure 1202435.006.

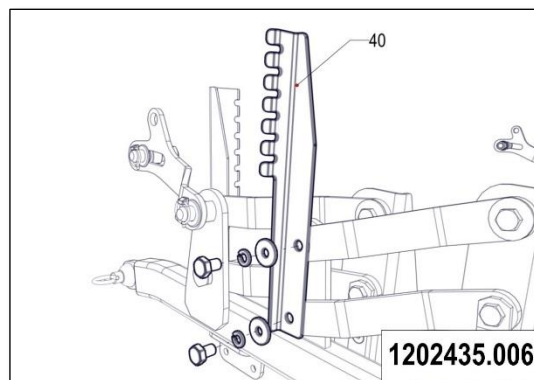

- Enlever la vis, la rondelle élastique bombée et l'écrou.

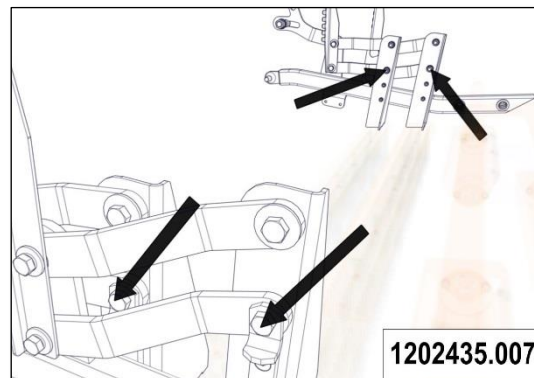

- Fixer le ressort (50) de traction au moyen de la vis à oeillet longue (70) depuis l'extérieur, à la place de la vis déposée à droit avec la rondelle en U (100), le rondelle élastique bombée (90) et la écrou hexagonal (80). (voir figure 1202435.008)

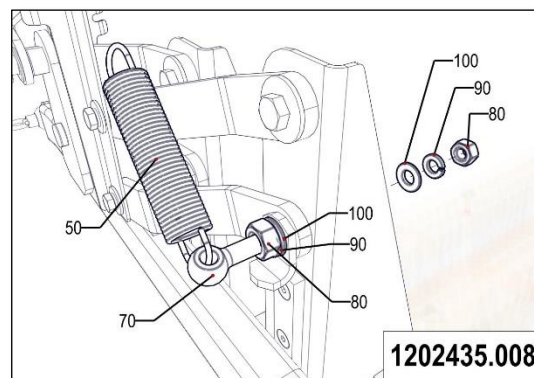

- Fixer le ressort (50) de traction au moyen de la vis à oeillet longue (70) depuis l'extérieur, à la place de la vis déposée à gauche avec la rondelle en U (100), le rondelle élastique bombée (90) et la écrou hexagonal (80). (voir figure 1202435.009)

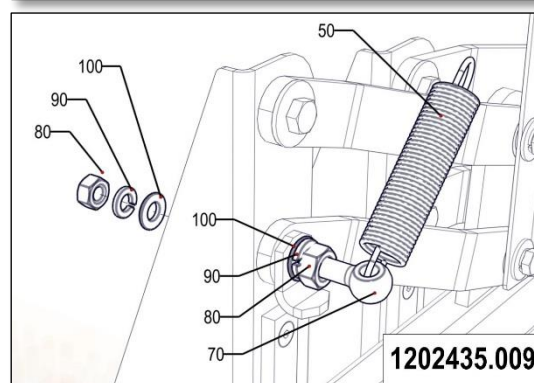

- Fixer le ressort (50) de traction au moyen de la vis à oeillet longue (60) depuis l'intérieur, à la place de la vis déposée à droit avec la rondelle en U (100), le rondelle élastique bombée (90) et la écrou hexagonal (80). (voir figure 1202435.010)

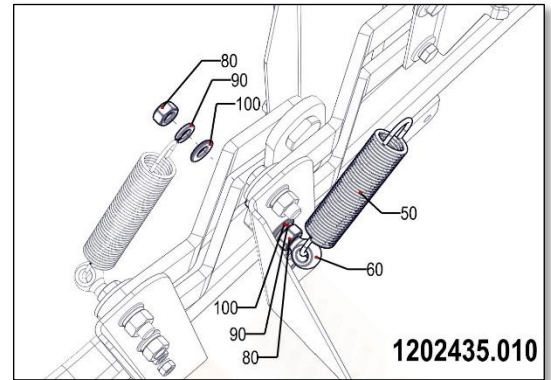

- Fixer le ressort (50) de traction au moyen de la vis à oeillet longue (60) depuis l'intérieur, à la place de la vis déposée à gauche avec la rondelle en U (100), le rondelle élastique bombée (90) et la écrou hexagonal (80). (voir figure 1202435.011)

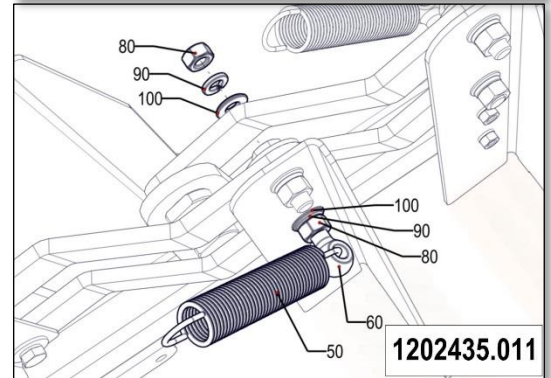

### 4.3. Réglage du kit de délestage

Le kit de délestage réduit la profondeur de pénétration des dents dans les gazons artificiels (option obligatoire) ou dans les gazons sensibles (option).

#### 4.3.1 Réglage pour les gazons artificiels

Le kit de délestage doit être en place avant l'utilisation sur les gazons artificiels.

Tous les ressorts de traction sont accrochés sur la position 1 ou 2.

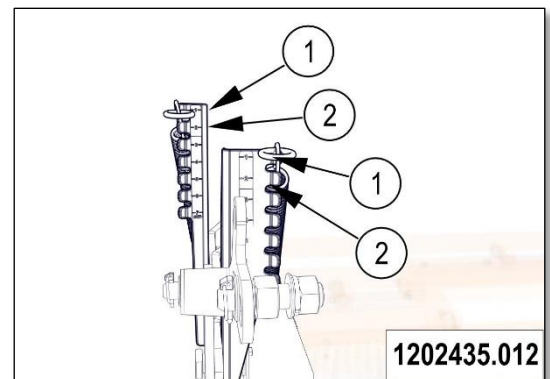

#### 4.4. Réglage pour les gazons

Lorsque le kit de délestage est en place, tous les ressorts de traction sont accrochés sur les positions 3 à 7.

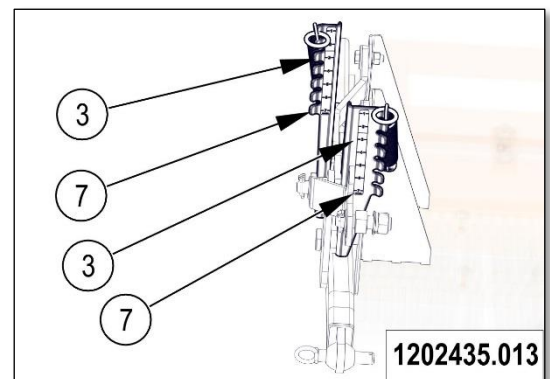

- Accrocher les ressorts de traction (50) sur la position souhaitée au niveau de supports de ressorts.

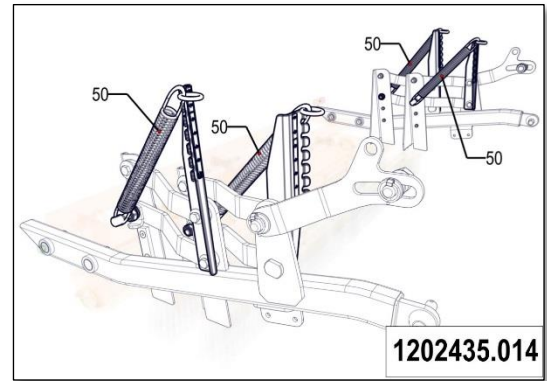

## 5. ES

### 5.1. A modo de introducción

#### 5.1.1 Terra Rake

Este aparato está diseñado exclusivamente al uso industrial y al empleo habitual en terrenos planos en la agricultura y silvicultura, para el mantenimiento de zonas verdes y parques y para abrir y raspar la superficie del suelo, así como para eliminar césped compacto.

Para un empleo ampliado para el mullido del material de relleno sobre superficies de hierba artificial. Para el empleo sobre superficies de hierba artificial es necesario que esté montado el equipamiento "Kit de descarga". ("Aplicación conforme al uso previsto")

#### 5.1.2 Terra Float Air

Este aparato está diseñado exclusivamente para uso industrial y construido para su empleo habitual en las zonas verdes y ajardinadas, a fin de garantizar una mejor disponibilidad de los campos de golf, tees y otros tipos de césped deportivo sin necesidad de realizar modificaciones ("APLICACIÓN CONFORME AL USO PREVISTO").

Los equipos opcionales de siembra complementaria sirven exclusivamente para el esparcido de semillas sueltas. Para el empleo sobre superficies de hierba artificial es necesario que esté montado el equipamiento "Kit de descarga". ("Aplicación conforme al uso previsto").



## 5.2. Montar el kit de descarga



### ¡ATENCIÓN - PELIGRO!

- ¡Para el montaje del kit de descarga es necesario aparcar el aparato sobre una superficie firme y nivelada!

- Retirar el tornillo, el anillo elástico y la arandela. La arandela desmontada se sustituye por otra (En ambos lados)

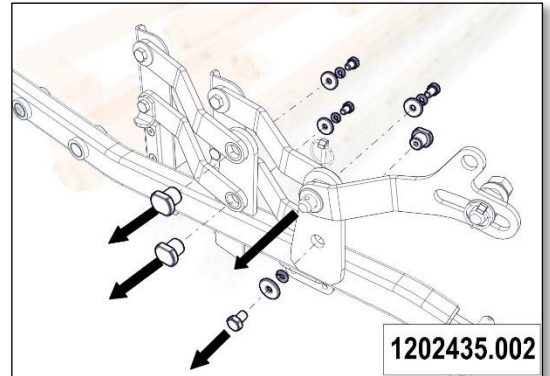

- Fijar el soporte elástico I (20) a la derecha con la arandela, el anillo elástico y el tornillo según lo indica la ilustración 1202435.003.

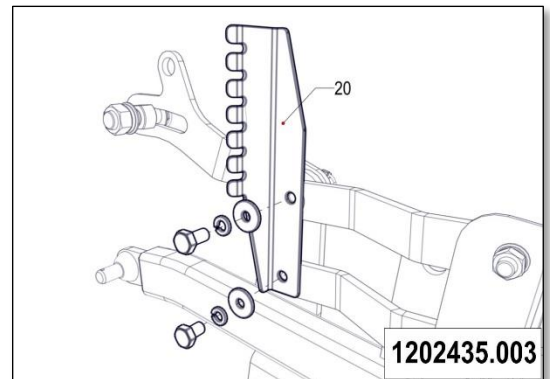

- Fijar el soporte elástico I (10) a la izquierda con la arandela, el anillo elástico y el tornillo según lo indica la ilustración 1202435.004.

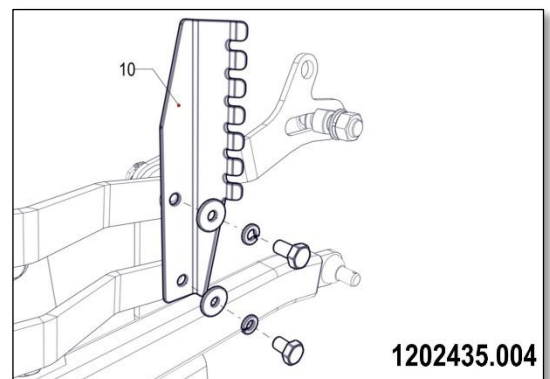

- Fijar el soporte elástico II (30) a la derecha con la arandela, el anillo elástico y el tornillo según lo indica la ilustración 1202435.005.

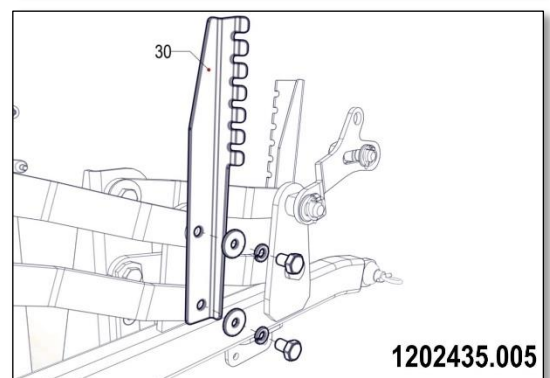

- Fijar el soporte elástico II (40) a la izquierda con la arandela, el anillo elástico y el tornillo según lo indica la ilustración 1202435.006.

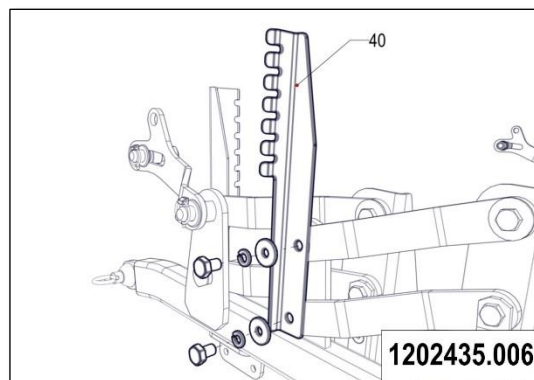

- Retirar el tornillo, el anillo elástico y la tuerca.

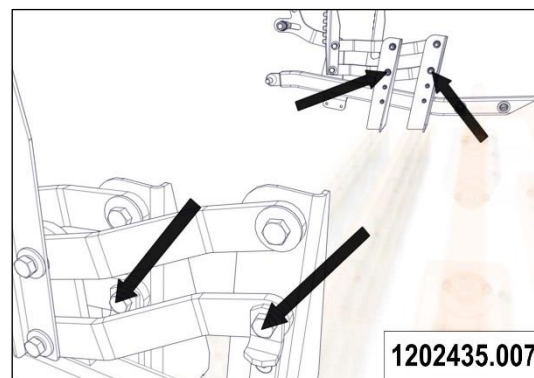

- Fijar el resorte de tracción (50) con el cáncamo largo (70) desde fuera en el lugar del tornillo desmontado a la derecha con la arandela (100), el anillo elástico (90) y el tuerca hexagonal (80). (ver la ilustración 1202435.008)

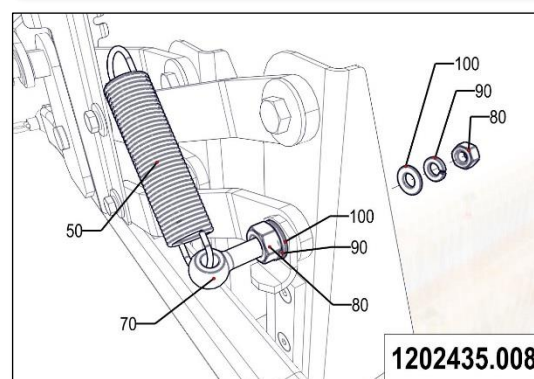

- Fijar el resorte de tracción (50) con el cáncamo largo (70) desde fuera en el lugar del tornillo desmontado a la izquierda con la arandela (100), el anillo elástico (90) y el tuerca hexagonal (80). (ver la ilustración 1202435.009)

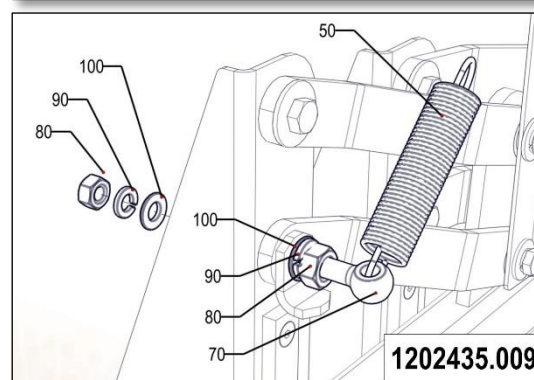

- Fijar el resorte de tracción (50) con el cáncamo corto (60) desde dentro en el lugar del tornillo desmontado a la derecha con la arandela (100), el anillo elástico (90) y el tuerca hexagonal (80). (ver la ilustración 1202435.010)

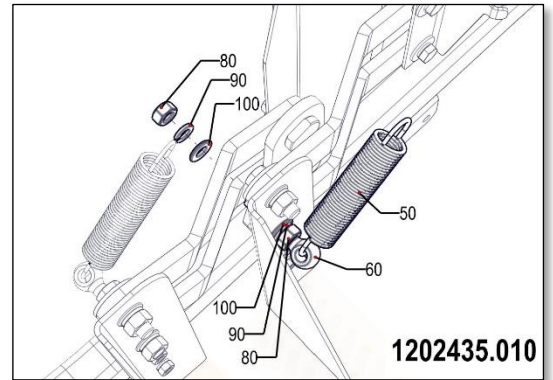

- Fijar el resorte de tracción (50) con el cáncamo corto (60) desde dentro en el lugar del tornillo desmontado a la izquierda con la arandela (100), el anillo elástico (90) y el tuerca hexagonal (80). (ver la ilustración 1202435.011)

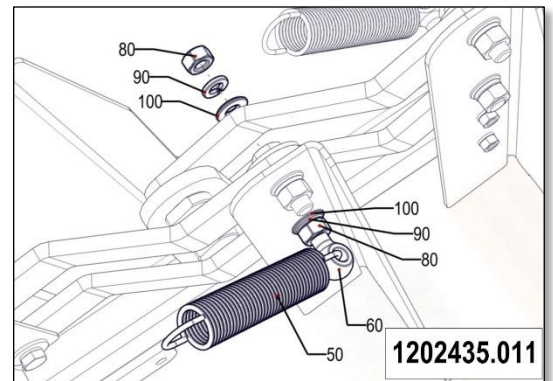

### 5.3. Ajustar el kit de descarga

El kit de descarga sirve para reducir la profundidad de penetración de las púas huecas sobre superficies de hierba artificial (opción obligatoria) o sobre superficies de césped sensibles (opción).

#### 5.3.1 Ajuste para superficies de hierba artificial

Previamente al empleo sobre superficies de hierba artificial debe haberse montado el kit de descarga.

Todos los resortes de tracción están suspendidas en la posición 1 o 2.

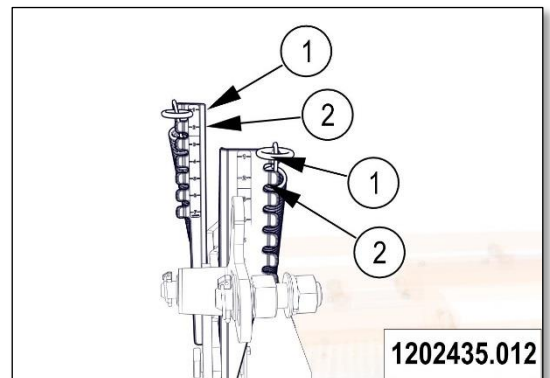

#### 5.3.2 Ajuste para superficies de césped

Si el kit de descarga está montado, todos los resortes de tracción están suspendidos en las porsiciones de 3 a 7.

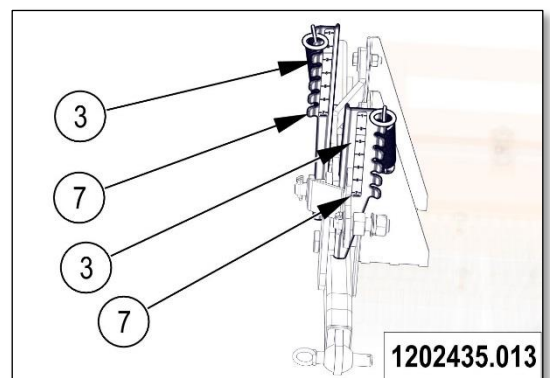

- Suspendere los resortes de tracción (50) en la posición deseada en los soportes elásticos.

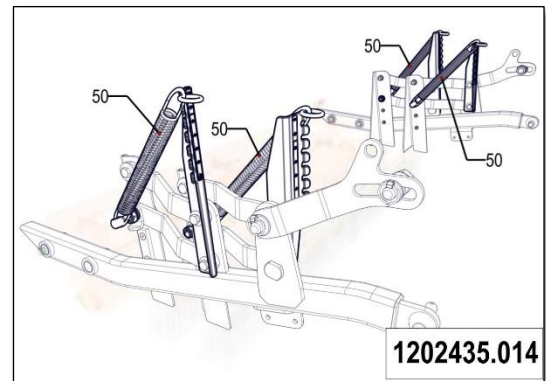

## 6. IT

### 6.1. Prefazione

#### 6.1.1 Terra Rake

Questo attrezzo è destinato esclusivamente per l'uso industriale e il normale impiego su terreno piano in agricoltura e silvicoltura, nelle cura di aree verdi ed impianti per rompere e granulare la superficie del terreno e per asportare strati erbosi.

È previsto un ulteriore utilizzo su prati artificiali allo scopo di smuovere il material di riempimento. Per l'uso su prati artificiali, deve essere montato l'equipaggiamento special "Kit di alleggrimento" (Uso secondo destinazione).

#### 6.1.2 Terra Float Air

Questo attrezzo è destinato esclusivamente all'uso professionale e al normale impiego nella manutenzione di aree verdi e giardini, per lavorare, dissodare o aerare campi sportivi e da golf.

Ogni altro impiego è da considerarsi non conforme alla destinazione d'uso. È previsto un ulteriore utilizzo su prati artificiali allo scopo di smuovere il material di riempimento. Per l'uso su prati artificiali, deve essere montato l'equipaggiamento special "Kit di alleggrimento" (Uso secondo destinazione).

### 6.2. Montaggio del kit di alleggrimento



#### **ATTENZIONE - PERICOLO!**

- Per il montaggio del kit de alleggrimento, l'apparecchio deve essere collocato in modo fermo su una superficie stabile piana!

- Rimuovere la vite, l'anello elastico e la rosetta a U. La rosetta a U smontata, deve essere sostituita (Da entrambi i lati)

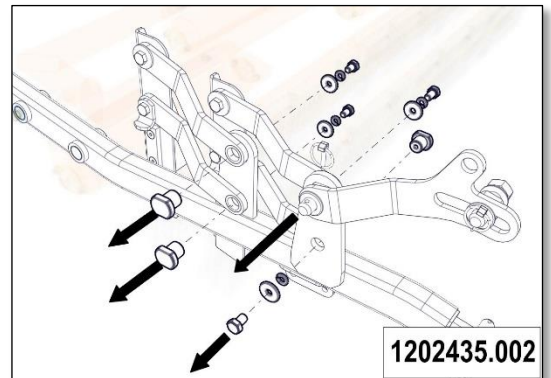

- Fissare il supporto molle I (20) a destra con la rosetta a U, l'anello elastico e la vite, come illustrato nella figura 1202435.003.

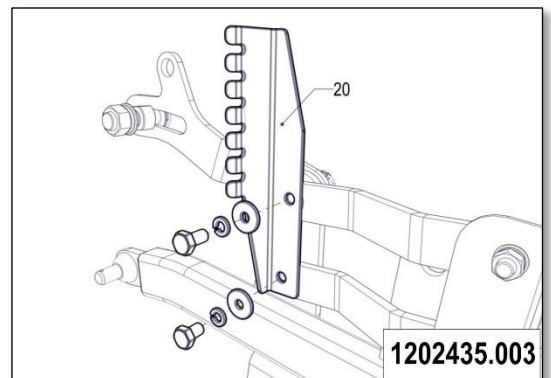

- Fissare il supporto molle I (10) a sinistra con la rosetta a U, l'anello elastico e la vite, come illustrato nella figura 1202435.004.

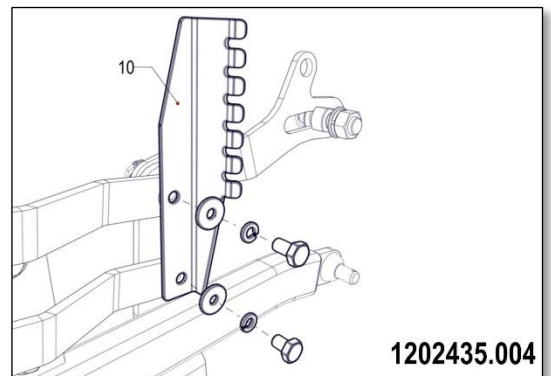

- Fissare il supporto molle II (30) a destra con la rosetta a U, l'anello elastico e la vite, come illustrato nella figura 1202435.005.

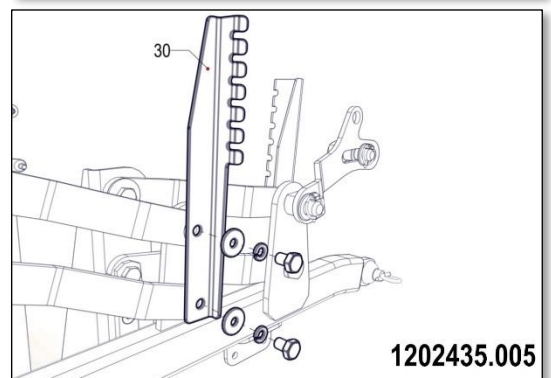

- Fissare il supporto molle II (40) a sinistra con la rosetta a U, l'anello elastico e la vite, come illustrato nella figura 1202435.006.

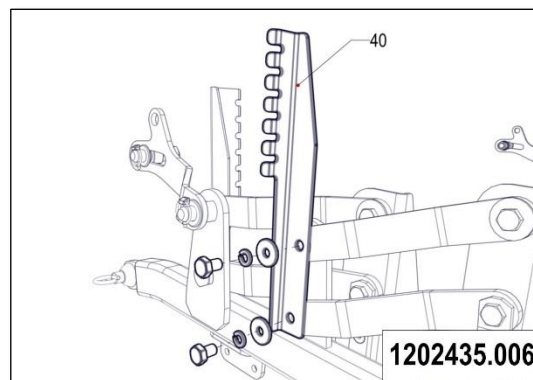

- Rimuovere la vite, l'anello elastico e il dado.

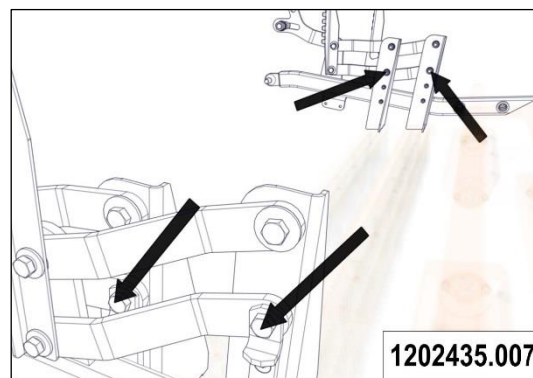

- Fissare la molla tenditrice (50) con la vite a golfare (70) dall'esterno, in maniera che risulti lunga, al posto della vite destra smontata con rondella a U (100), anello elastico (90) e dado esagonale (80). (vedere figura 1202435.008)

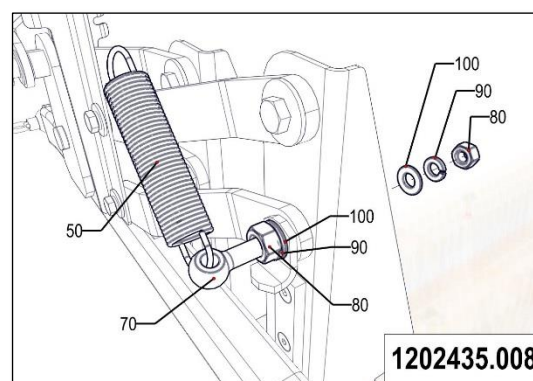

- Fissare la molla tenditrice (50) con la vite a golfare (70) dall'esterno, in maniera che risulti lunga, al posto della vite sinistra smontata con rondella a U (100), anello elastico (90) e dado esagonale (80). (vedere figura 1202435.009)

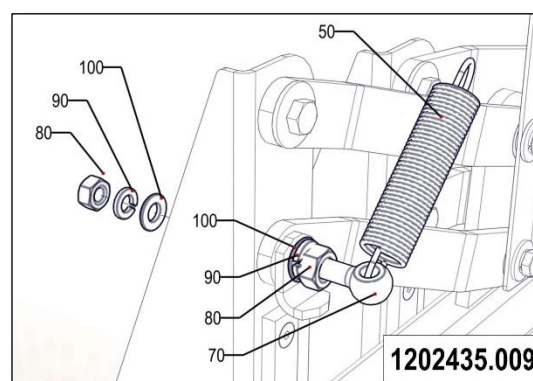

- Fissare la molla tenditrice (50) con la vite a golfare (60) dall'interno, in maniera che risulti corta, al posto della vite destra smontata con rondella a U (100), anello elastico (90) e dado esagonale (80). (vedere figura 1202435.010)

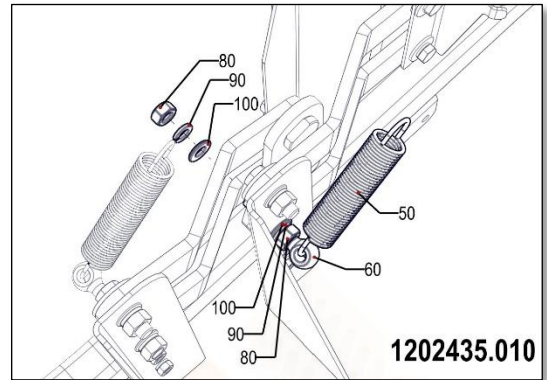

- Fissare la molla tenditrice (50) con la vite a golfare (60) dall'interno, in maniera che risulti corta, al posto della vite sinistra smontata con rondella a U (100), anello elastico (90) e dado esagonale (80). (vedere figura 1202435.011)

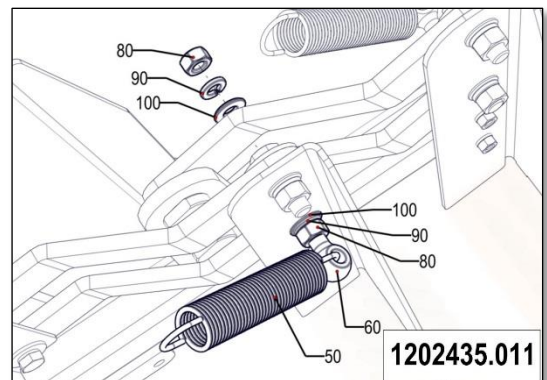

### 6.3. Regolazione del kit di alleggerimento

Il kit di alleggerimento riduce la profondità di penetrazione dei denti nei prati artificiali (obbligatorio) o su prati sensibili (opzionale).

#### 6.3.1 Regolazione per i prati artificiali

Prima dell'uso su prati artificiali, deve essere montato il kit di alleggerimento.

Tutte le molle tenditrici sono agganciate nella posizione 1 o 2.

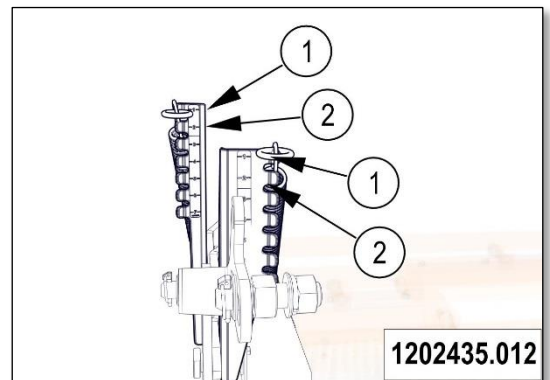

#### 6.3.2 Regolazione per prati

Con kit di alleggerimento montato, tutte le molle tenditrici sono agganciate alle posizioni da 3 a 7.

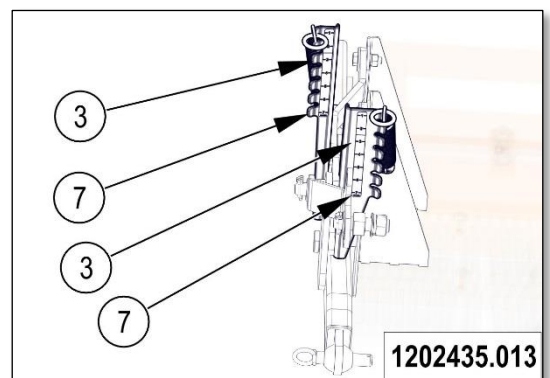

- Agganciare la molle tenditrici (50) nella posizione desiderata sul supporto molle.

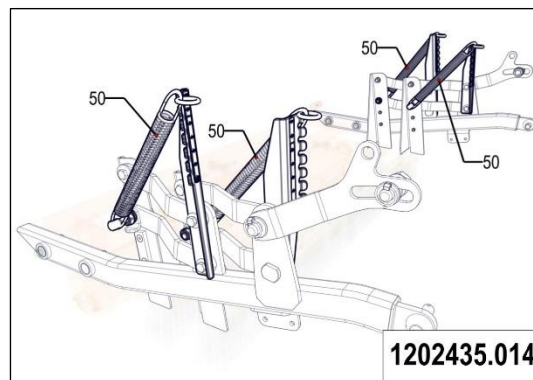

## 7. NL

### 7.1. Voorwoord

#### 7.1.1 Terra Rake

Dit werktuig is uitsluitend voor het professionele gebruik en het normale gebruik op effen terrain in de land- en bosbouw, voor het onderhoud van plantsoenen ontworpen. Het werktuig dient voor het opentrekken en ruwen van het bodemoppervlak en voor het verwijderen van gazonvilt.

Voor het uitgebreide gebruik op kunstgras om het vulmateriaal los te maken. Voor het gebruik op kunstgras moet de speciale uitrusting „ontlastingskit“ aangebouwd zijn.

#### 7.1.2 Terra Float Air

Dit werktuig is uitsluitend bestemd voor het professionele en normale gebruik bij het onderhoud van plantsoenen om op niet steenachtige en onbevoren bodem een betere duurzaamheid van golf greens, tees en andere sportgazons te verkrijgen zonder om te ploegen ("DOELMATIG GEBRUIK").

De optionele bijzaaimachines dienen uitsluitend voor het verspreiden van strooibaar zaadgoed. Voor het uitgebreide gebruik op kunstgras om het vulmateriaal los te maken. Voor het gebruik op kunstgras moet de speciale uitrusting „ontlastingskit“ aangebouwd zijn („Doelmatig gebruik“).

### 7.2. Ontlastingskit monteren



#### **ATTENTIE - GEVAAR!**

- Voor de montage van de ontlastingskit moet het toestel op een effen en verhard opeervlak geplaatst worden!



- Schroef, veerring en U-schijf verwijderen. De gedemonteerde U-schijf wordt vervangen (Aan beide kanten)

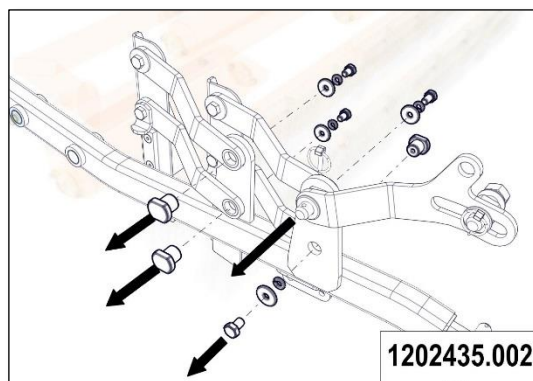

- Veerhouder I (20) rechts met U-schijf, veerring en schroef zoals op afbeelding 1202435.003 bevestigen.

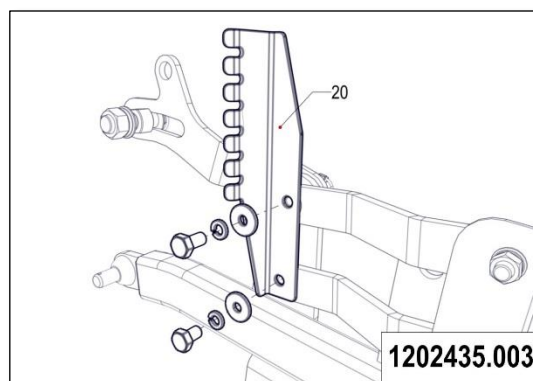

- Veerhouder I (10) links met U-schijf, veerring en schroef zoals op afbeelding 1202435.004 bevestigen.

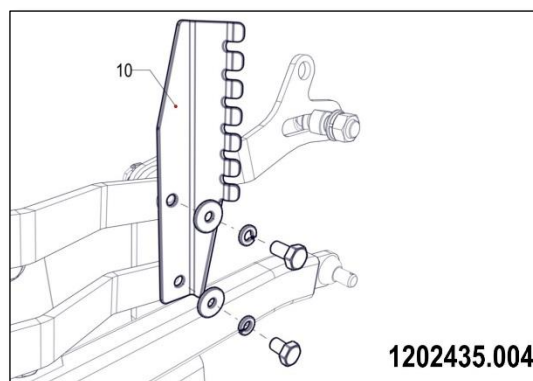

- Veerhouder II (30) rechts met U-schijf, veerring en schroef zoals op afbeelding 1202435.005 bevestigen.

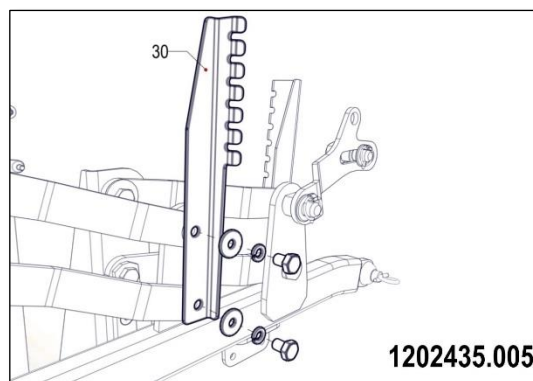

- Veerhouder II (40) links met U-schijf, veerring en schroef zoals op afbeelding 1202435.006 bevestigen.

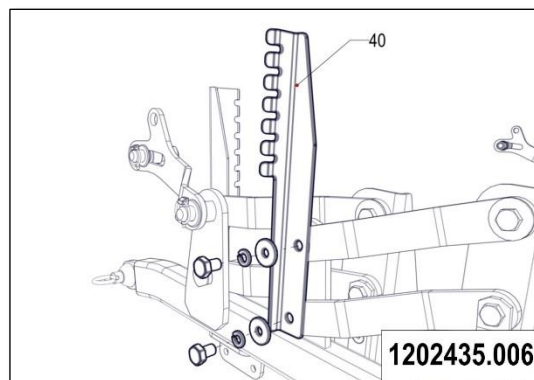

- Schroef, veerring en moer verwijderen.

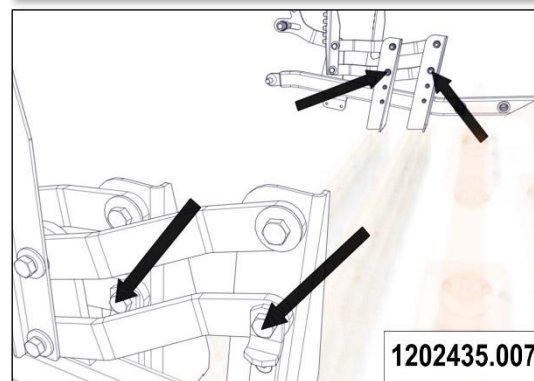

- Trekveer (50) met oogschroef lang (70) van buiten op de plaats van de gedemonteerde schroef rechts met U-schijf (100), veerring (90) en zeskantige moer (80) bevestigen.  
(zie afbeelding 1202435.008)

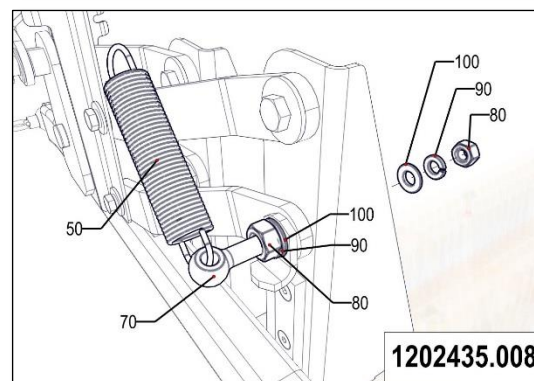

- Trekveer (50) met oogschroef lang (70) van buiten op de plaats van de gedemonteerde schroef links met U-schijf (100), veerring (90) en zeskantige moer (80) bevestigen.  
(zie afbeelding 1202435.009)

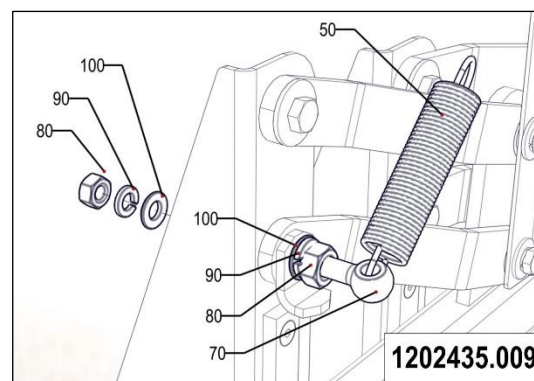

- Trekveer (50) met oogschroef kort (60) van binnen op de plaats van de gedemonteerde schroef rechts met U-schijf (100), veerring (90) en zeskantige moer (80) bevestigen.  
(zie afbeelding 1202435.010)

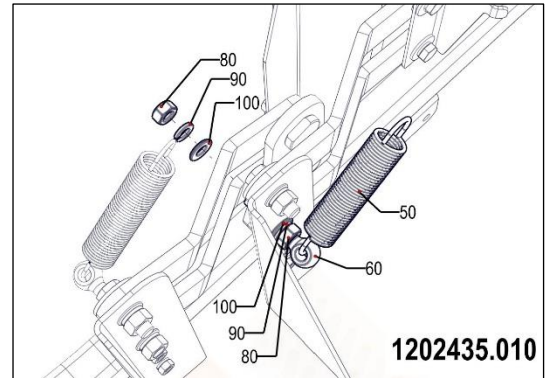

- Trekveer (50) met oogschroef kort (60) van binnen op de plaats van de gedemonteerde schroef links met U-schijf (100), veerring (90) en zeskantige moer (80) bevestigen.  
(zie afbeelding 1202435.010)

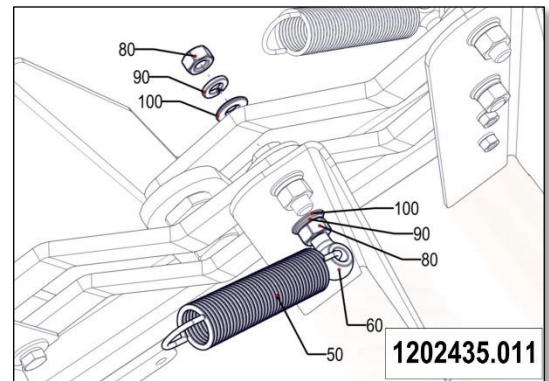

### 7.3. Ontlastingskit instellenn

De ontlastingskit reduceert de indringdiepte van de tanden op kunstgras (verplichte optie) of op gevoelig gazon (optie).

#### 7.3.1 Instelling voor kunstgras

Voor het gebruik op kunstgras moet de ontlastingskit gemonteerd zijn.

Alle trekveren zijn op de positie 1 of 2 ingehangen.

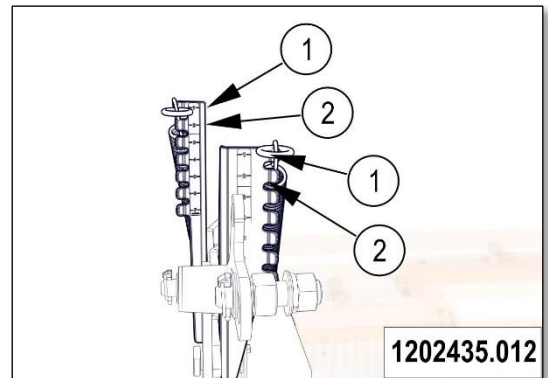

#### 7.3.2 Instelling voor gazon

Bij gemonteerde ontlastingskit zijn alle trekveren op de posities 3 tot 7 ingehangen.

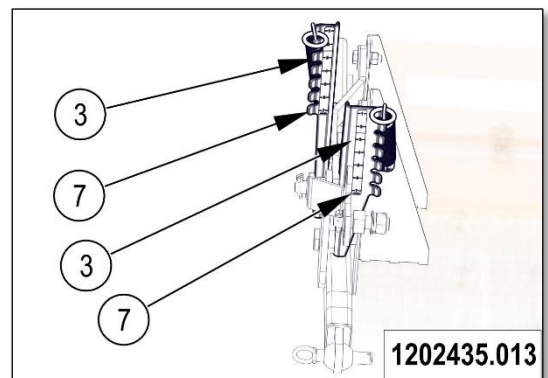

- Trekveren (50) op de gewenste positie aan de veerhouders inhangen.

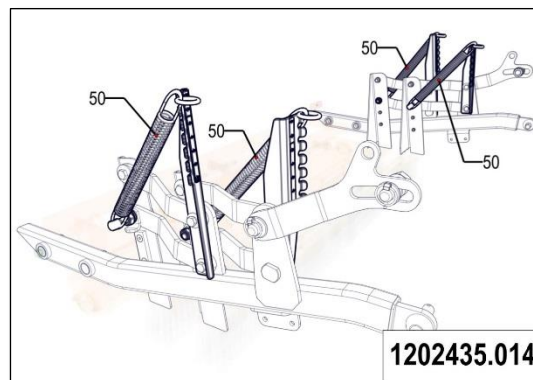

## 8. US

### 8.1. Introduction

#### 8.1.1 Introduction

The machine is designed exclusively for commercial use and for normal application on flat ground in agriculture and forestry and the maintenance of grassy areas and parks and are used for breaking and roughening the ground surface and also for removing grass residue.

For extended use on artificial turf to loosen the filler material. The "relief kit" special equipment must be attached for operation on artificial turf ("Intended use").

#### 8.1.2 Terra Float Air

The machine is designed exclusively for commercial use and standard applications in the maintenance of grass and turf, for continually improving the state of golf greens, tees and other sports fields on ground with no stones and on unfrozen ground.

The optional sod seeders are used exclusively for the application of free-flowing seed. For extended use on artificial turf to loosen the filler material. The "relief kit" special equipment must be attached for operation on artificial turf ("Intended use").

### 8.2. Mounting relief kit



#### CAUTION - DANGER!

- Park the tractor on a firm, flat surface to mount the relief kit!

- Remove screw, lock washer and U-washer. The removed U-washer is replaced. (On both sides)

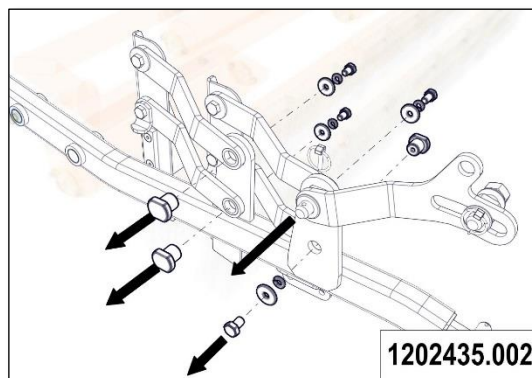

- Fasten spring retainer (20) right with U-washer, lock washer and screw as shown in Fig. 1202435.003.

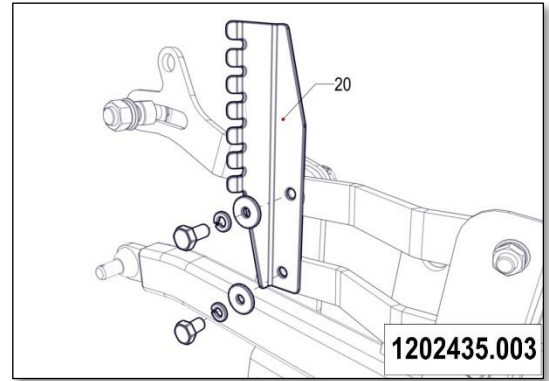

- Fasten spring retainer I (10) left with U-washer, lock washer and screw as shown in Fig. 1202435.004.

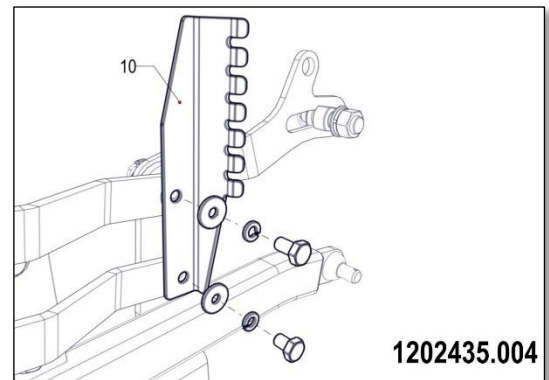

- Fasten spring retainer (30) right with U-washer, lock washer and screw as shown in Fig. 1202435.005.

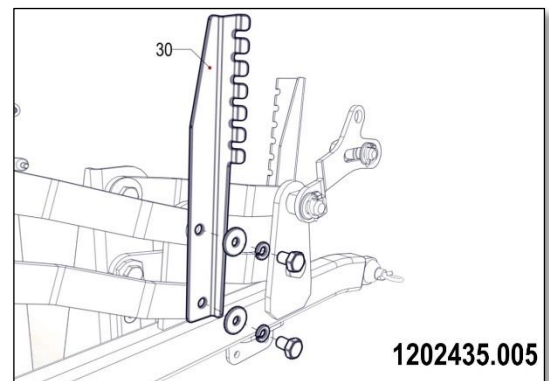

- Fasten spring retainer II (40) left with U-washer, lock washer and screw as shown in Fig. 1202435.006.

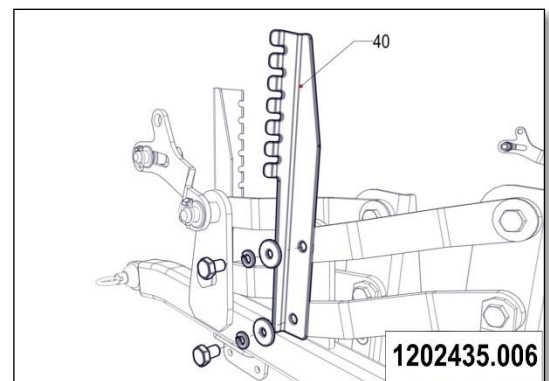

- Remove screw, lock washer and nut.

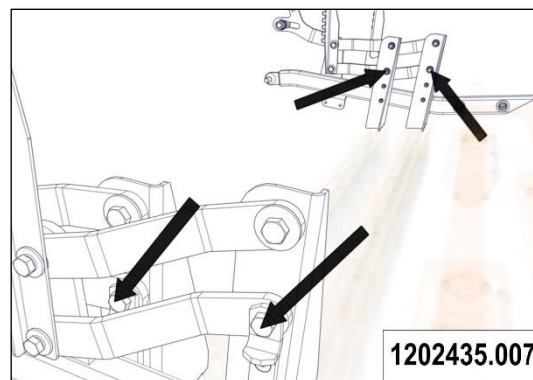

- Fasten tension spring (50) with long eye bolt (70) from outside in the position of the removed screw on the right with U-washer (100), lock washer (90) and hexagonal nut (80). (see Fig. 1202435.008)

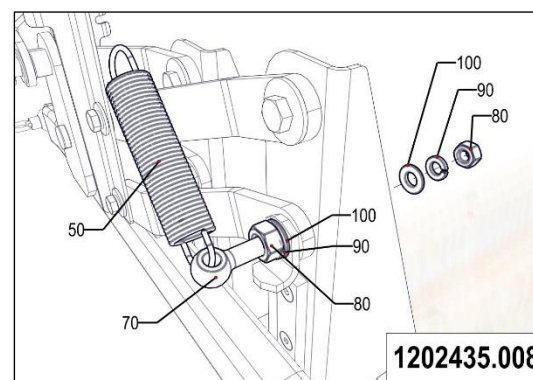

- Fasten tension spring (50) with long eye bolt (70) from outside in the position of the removed screw on the left with U-washer (100), lock washer (90) and hexagonal nut (80). (see Fig. 1202435.009)

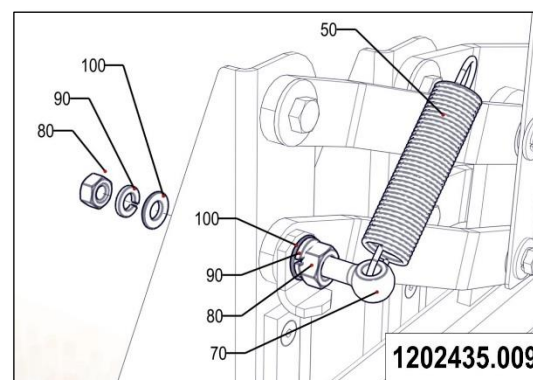

- Fasten tension spring (50) with short eye bolt (60) from inside in the position of the removed screw on the right with U-washer (100), lock washer (90) and hexagonal nut (80). (see Fig. 1202435.010)

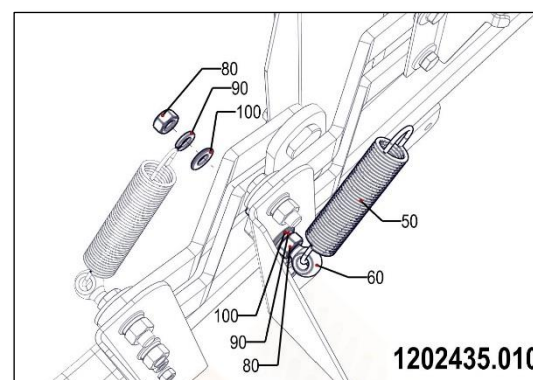

- Fasten tension spring (50) with short eye bolt (60) from inside in the position of the removed screw on the left with U-washer (100), lock washer (90) and hexagonal nut (80). (see Fig. 1202435.011)

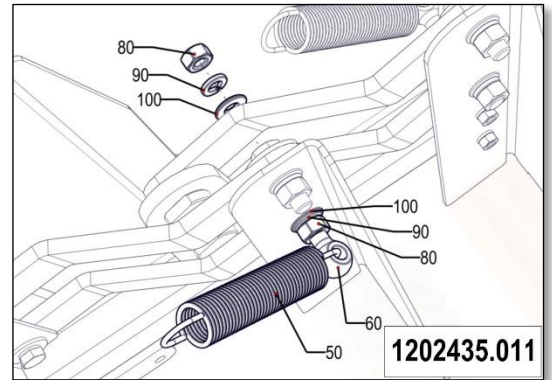

### 8.3. Adjusting relief kit

The relief kit reduces the penetration depth of the hollow tines on artificial turf (required option) or sensitive lawns (optional).

#### 8.3.1 Adjustment for artificial turf

The relief kit must be mounted before operation on artificial turf.  
All tension springs are attached at position 1 or 2.

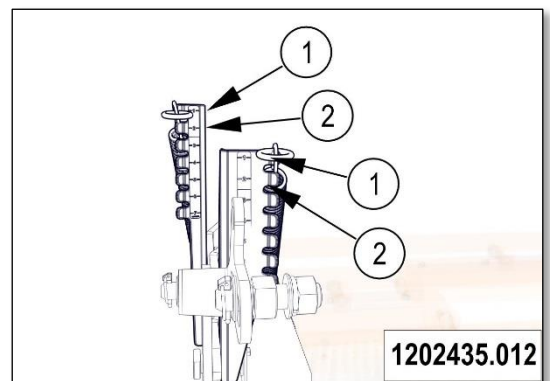

#### 8.3.2 Adjustment für lawns

All tension springs are attached at position 3 to 7 with the relief kit installed.

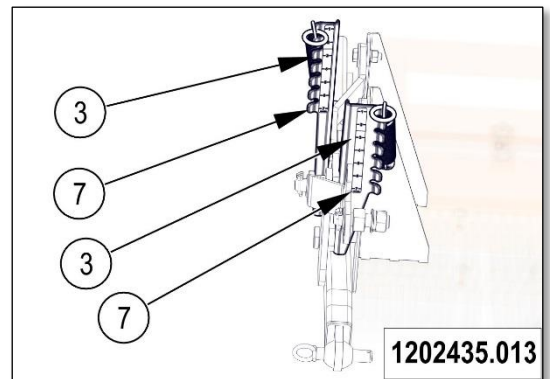

- Attach tension springs (50) to the spring retainers at the required position.

