



**Translation of original  
Operating Instructions**

**Snow Rake Blade  
Snow Master VARIO  
Series 3350**

**3350.002**

**From equipment I.D. No. :**

**Status :                      October 2012**

**3350 99 01**



# EC DECLARATION OF CONFORMITY

We

**Wiedenmann GmbH  
Am Bahnhof  
89192 Rammingen**

declare under our sole responsibility that the product

**Snow Rake Blade Snow Master VARIO  
Series 3350**

to which this declaration refers, corresponds with the relevant basic safety and health requirements of the machinery directive 2006/42/EC.

	
<b>Rammingen, the 29.10.2012</b>	<b>Horst Wiedenmann</b>
(Place and date of issue)	<b>Managing Partner</b>
	(Name, function and signature of authorised person)

	
<b>Rammingen, the 29.10.2012</b>	<b>Peter Rischar</b>
(Place and date of issue)	<b>Technical office manager Authorised representative for tech. documentation</b>
	(Name, function and signature of authorised person)

**NOTE: The declaration of conformity is no longer valid if changes are made to the machine that have not been agreed with the manufacturer.**



## Declaration of conformity

We

Wiedenmann GmbH  
Am Bahnhof  
89192 Rammingen

hereby declare that the product

### Snow Rake Blade Snow Master VARIO Series 3350

referred to by this declaration complies with the requirements of  
Machinery Directive 2006/42/EC.

	
<b>Rammingen, the 29.10.2012</b>	<b>Karl Wiedenmann</b>
(Place and date of issue)	<b>Sales Manager</b>
	(Name, function and signature of authorised person)
	
<b>Rammingen, the 29.10.2012</b>	<b>Harald Reuen</b>
(Place and date of issue)	<b>Operations Manager</b>
	(Name, function and signature of authorised person)

Wiedenmann GmbH  
Am Bahnhof  
D 89192 Rammingen  
Tel. No. : +49 (0) 7345 / 953-0  
Fax No. : +49 (0) 7345 / 953 233  
E-mail : [info@wiedenmann.de](mailto:info@wiedenmann.de)  
Internet : <http://www.wiedenmann.de>

# Preface

**READ THESE OPERATING INSTRUCTIONS CAREFULLY** to familiarise yourself with the correct way to operate and service your machine, and to prevent personal injury or damage to the machine.

**THESE OPERATING INSTRUCTIONS BELONG** to the machine and should be handed over to the new owner if the machine is sold.

**MEASUREMENTS** in these Operating Instructions are given in the metric system. Furthermore, the corresponding US dimensions are also stated in each case. Only use suitable parts and screws. Different wrenches are required for metric and inch screws.

**THE DESIGNATIONS "RIGHT" AND "LEFT"** refer to the forward driving direction of the mounted equipment.

**ENTER THE PRODUCT IDENTIFICATION NUMBERS** in the appropriate "Technical data" or "Product - Identification Number" sections. Please ensure that all figures are accurately entered. These numbers can be of invaluable assistance for tracing the machine should it be stolen. Your dealer also needs these numbers when you order spare parts. We recommend that you additionally file these identification numbers in a secure place away from the machine.

**BEFORE DELIVERY OF THIS MACHINE,** your dealer performed a pre-delivery inspection to ensure optimal performance.

**THIS MACHINE IS DESIGNED EXCLUSIVELY** for winter services clearing snow from roads and grassy areas ("SPECIFIED USE").

Usage for any other purpose beyond this is considered as contrary to the intended use. The manufacturer accepts no liability for damage or injury resulting from this improper use. These risks are borne solely by the user. Using the equipment in accordance with the specifications also includes observance of the operating and maintenance conditions as specified by the manufacturer.

**FORESEEABLE INCORRECT USE/MISUSE.** It is not permitted to use the attached device to transport persons or things.

**THIS MACHINE MUST ONLY** be operated, maintained and repaired by personnel familiar with the equipment and who are aware of the dangers involved. The relevant accident prevention regulations, all other generally recognised safety-related, occupational medicine and road traffic regulations must be adhered to. Unauthorised modification to the machine exonerates the manufacturer from liability for any resulting damage.



# TABLE OF CONTENTS

Page

\*\*\*\*\*

1.0. Safety Measures.....	6-13
1.1. Safety decals.....	11-12
1.2. Safety instructions.....	13
2.0. Assembly.....	14-20
2.1. General Information.....	14
2.2. Mounting the scraping edges.....	14+15
2.3. Mounting of skid shoes.....	16
2.4. Installing the support wheels.....	17
2.5. Mounting the lighting unit.....	18
2.6. Installing the blade adjustment.....	19
2.7. Two-fold control block expansion.....	20
3.0. Transport.....	21-23
3.1. General Information.....	21
3.2. Transporting the Snow Master Vario.....	22
3.3. Transport.....	23
4.0. Connecting to the Tractor.....	24-27
4.1. General Information.....	24
4.2. The correct position of the installation trestle.....	24
4.3. Attaching with A-frame cat. 0 A.....	25
4.4. Attaching with triangular coupling B.....	25
4.5. Attaching with three-point frame C.....	26
4.6. Raising the support.....	26
4.7. Connecting hydraulics.....	27
4.8. Ballast.....	27
5.0. Disconnecting from the Tractor.....	28-29
5.1. General Information.....	28
5.2. Lowering the support.....	28
5.3. Releasing the hydraulic connection.....	28
5.4. Removal with A-frame cat. 0 A.....	29
5.5. Removal with triangular coupling B.....	29
5.6. Removal with three-point frame C.....	29
6.0. Before Initial Operation.....	30-31
6.1. General Information.....	30
6.2. Adjusting the support wheels.....	30
6.3. Adjusting the sliding shoes.....	31
7.0. Operation.....	32-33
7.1. General Information.....	32
7.2. Driving characteristics.....	32
7.3. Working with the SNOW MASTER VARIO.....	33
7.4. Malfunctions and troubleshooting.....	33
8.0. Maintenance.....	34-41
8.1. General Information.....	34
8.2. Maintenance and inspection list.....	35
8.3. Lubrication.....	36
8.4. Cleaning the SNOW MASTER VARIO.....	37
8.5. Hydraulics system.....	38
8.6. Hydraulic connection diagram.....	39-40
8.7. Disassembly / disposal.....	41
8.8. Unauthorised modification and spare part manufacturing....	41
9.0. Equipment.....	42-47
9.1. Scope of Delivery.....	42
9.2. Tines Set.....	42
9.3. Attachment parts.....	43-46
9.4. Special equipment.....	47
10.0. Technical Specifications.....	48-55

# 1.0. Safety

## Recognize safety information

This is the safety-alert symbol. When you see this symbol on your machine or in this manual, be alert to the potential for personal injury.

Follow recommended precautions and safe operating practices.



## Follow safety instructions

Carefully read all safety messages in this manual and on your machine safety signs. Keep safety signs in good condition. Replace missing or damaged safety signs. Be sure new equipment components and repair parts include the current safety signs. Replacement safety signs are available from your dealer.

Learn how to operate the machine and to use controls properly. Do not let anyone operate without instruction.

Keep your machine in proper working condition. Unauthorized modifications to the machine may impair the function and/or safety and affect machine life.

If you do not understand any part of this manual and need assistance, contact your dealer.

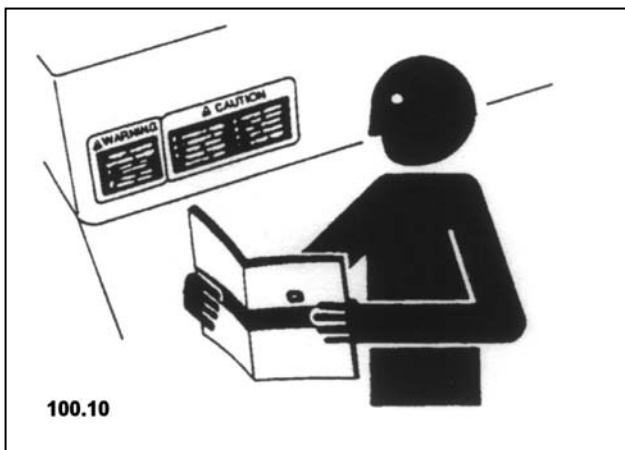

# 1.0. Safety

## Observe road traffic regulations

Always observe local road traffic regulations when using public roads.

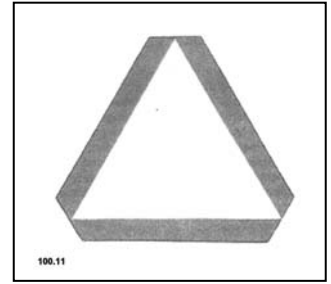

## Wear protective clothing

Wear close fitting clothing and safety equipment appropriate to the job.

Prolonged exposure to loud noise can cause impairment or loss of hearing.

Wear a suitable hearing protective device such as earmuffs or earplugs to protect against objectionable or uncomfortable loud noises.

Operating equipment safely requires the full attention of the operator. Do not wear radio or music headphones while operating machine.



## Stay clear of rotating drivelines

Entanglement in rotating driveline can cause serious injury or death.

Keep tractor master shield and driveline shields in place at all times. Make sure rotating shields turn freely.

Keep tractor master shield and driveline shields in place at all times. Make sure rotating shields turn freely.



# 1.0. Safety

## Guard and shields

Keep guards and shields in place all the times. Ensure that they are in good condition and installed correctly.

Always disengage the driveline, shut off engine and remove key before removing any guards or shields.

Keep hands, feet and clothing away from moving parts.

## Avoid high - pressure fluids

Escaping fluid under pressure can penetrate the skin causing serious injury.

Avoid the hazard by relieving pressure before disconnecting hydraulic or other lines. Tighten all connections before applying pressure.

Search for leaks with a piece of cardboard. Protect hands and body from high pressure fluids.

If an accident occurs, see a doctor immediately. Any fluid injected into the skin must be surgically removed within a few hours or gangrene may result.

Doctors unfamiliar with this type of injury should reference a knowledgeable medical source.





## 1.0. Safety

### Use safety lights and devices

Prevent collisions between other road users, slow moving tractors with attachments or towed equipment, and self-propelled machines on public roads. Frequently check for traffic from the rear, especially in turns, and use hand signals or turn signal lights.

Use headlights, flashing warning lights, and turn signals day and night. Follow local regulations for equipment lighting and marking. Keep lighting and marking visible and in good working order. Replace or repair lighting and marking that has been damaged or lost. An implement safety lighting kit is available from your dealer.

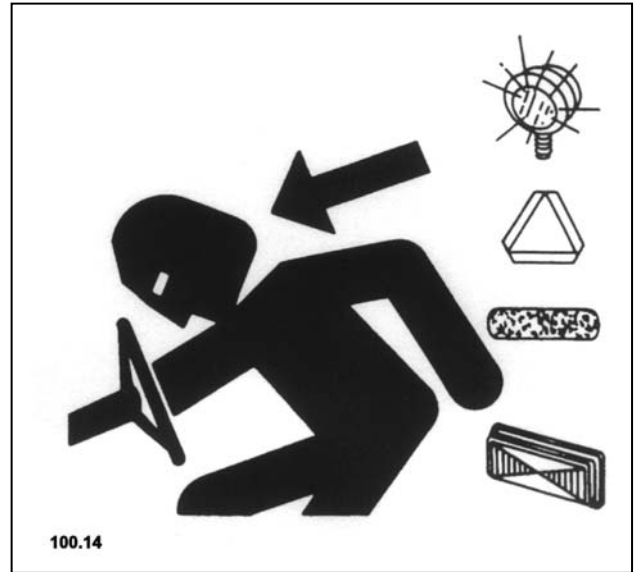

### Avoid heating near pressurized fluid lines

Flammable spray can be generated by heating near pressurized fluid lines, resulting in severe burns to yourself and bystanders. Do not heat by welding, soldering, using a torch near pressurized fluid lines or other flammable materials. Pressurized lines can be accidentally cut when heat goes beyond the immediate flame area.



# 1.0. Safety

## Remove paint before welding or heating

Welding should only be carried out by persons with a relevant qualifying certificate i.a.w. EN287.

Avoid potentially toxic fumes and dust.

Hazardous fumes can be generated when paint is heated by welding, soldering, or using a torch.

Do all work outside or in a well ventilated area. Dispose of paint and solvent properly.

Remove paint before welding or heatingh:

- If you sand or grind paint, avoid breathing the dust. Wear an approved respirator.
- If you use solvent or paint stripper with soap and water before welding. Remove solvent or paint stripper containers and other flammable material from area. Allow fumes to disperse at least 15 minutes before welding or heating.

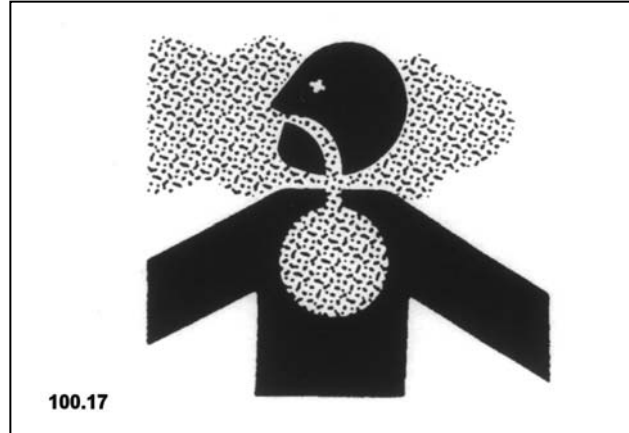

# 1.0. Safety Measures

## 1.1. Adhesive Safety Signs

### Warning symbols

Warning symbols indicating danger are attached at some important areas on the machine. The hazard is identified via a warning triangle. A second symbol informs you how the injury can be prevented by acting appropriately. These warning signs, their placement on the machine and a brief explanation are given below.



### Operating Instructions

These Operating Instructions contain all important information necessary for the safe operation of the machine. Carefully observe all safety instructions to avoid accidents.

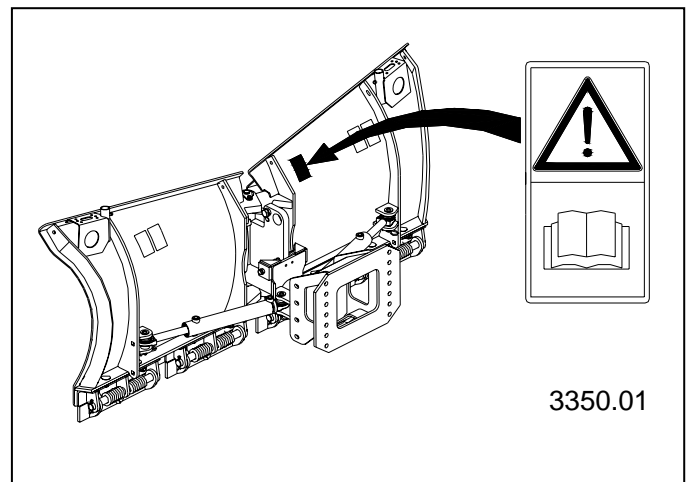

# 1.0. Safety Measures

## 1.1. Adhesive Safety Signs

### Danger of crushing through moving parts

Never reach into crushing hazard zones while parts located there can still move.

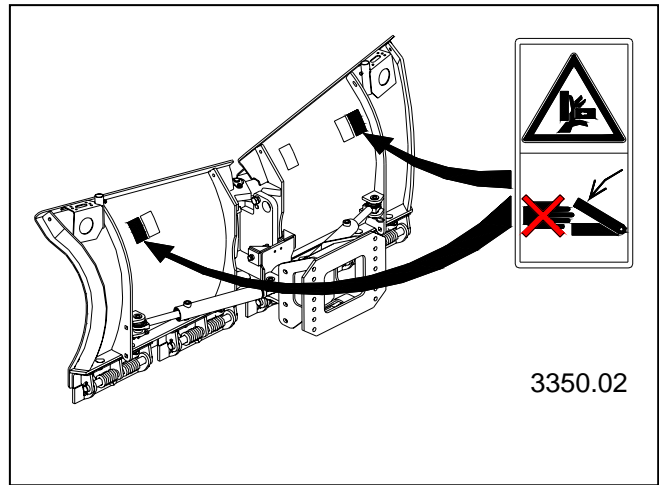

### Danger of crushing – stay clear of swivel area

When the tractor engine is running, stay clear of the swivel area of the rake blade.

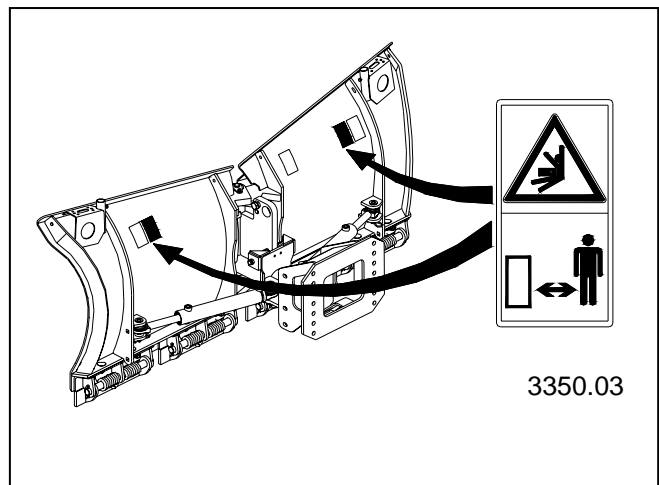

# 1.0. Safety Measures

## 1.2. Safety instructions



- In addition to the information provided in these Operating Instructions, please also observe generally applicable safety and accident-prevention standards !
- Familiarise yourself with all equipment and operating elements and their functions before starting work. It is too late to do this when you have started work!
- In the working area, the user is responsible for the safety of other persons !
- During operation on public highways, the relevant traffic regulations must be observed.
- Before moving off, ensure that the immediate area of the machine is clear e.g. no children nearby. Ensure that your visibility is not impaired !
- Keep all persons clear of the danger zone of the machine !
- Use only attachments prescribed for the machine on which they are being mounted.
- The driving and operational characteristics of the tractor may be influenced by the attachment of the rake blade. Always adapt your driving style to match the terrain and ground conditions.
- Special care should be taken when working and turning on a slope.
- Switch off the machine and the tractor motor when performing any maintenance.

## 2.0. Assembly

### 2.1. General Information

For this work, please use your personal protective equipment (PSA) such as: gloves, goggles, ear protectors.

### 2.2. Mounting the scraping edges

2.2.1. for model 3352 and 3357

Secure plastic scraping edges (A) in hole pattern.

Worn down scraping edges (A) must be renewed.

Secure steel scraping edges (B) in hole pattern.

Worn down scraping edges (B) must be renewed.

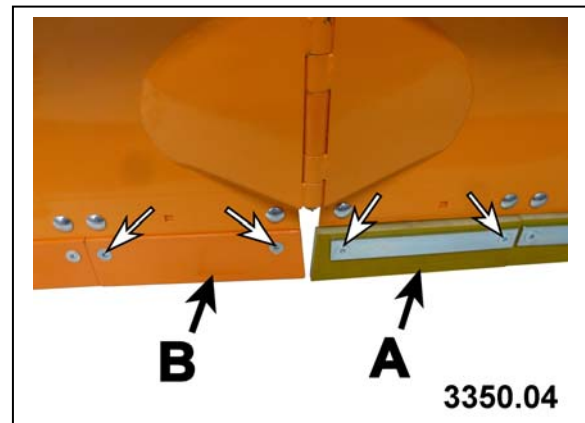

The interior scraping edges are to be installed so that the incline is to the inside.





## 2.0. Assembly

### 2.2. Mounting the scraping edges

2.2.2. for the models  
3353; 3354; 3355 and 3359

Secure plastic scraping edges (A) in hole pattern.

Worn down scraping edges (A) must be renewed.

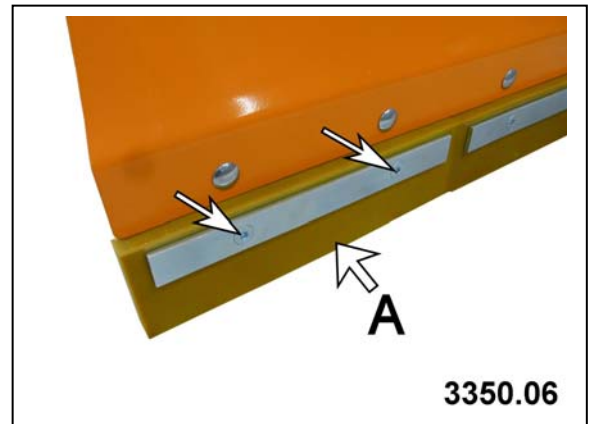

Secure steel scraping edges (B) in hole pattern.

Worn down scraping edges (B) must be renewed.

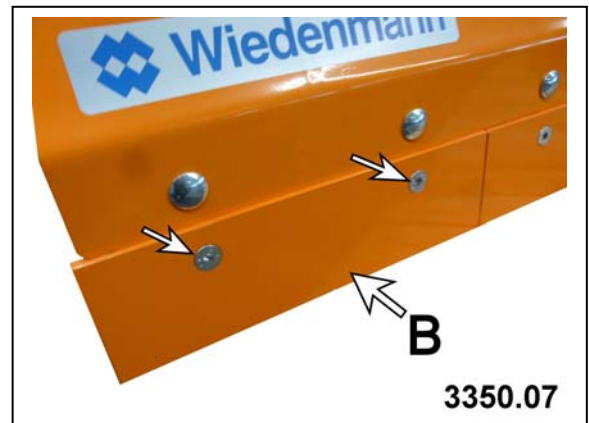

## 2.0. Assembly

### 2.3. Mounting of skid shoes

#### 2.3.1. for the models 3353; 3354 and 3355

Screw on skid shoes (A) in the available hole pattern on both sides.

Unhinge the hydraulic cylinder at the share plate to insert the top screw.

The figure shows the skid shoe on the right-hand side.

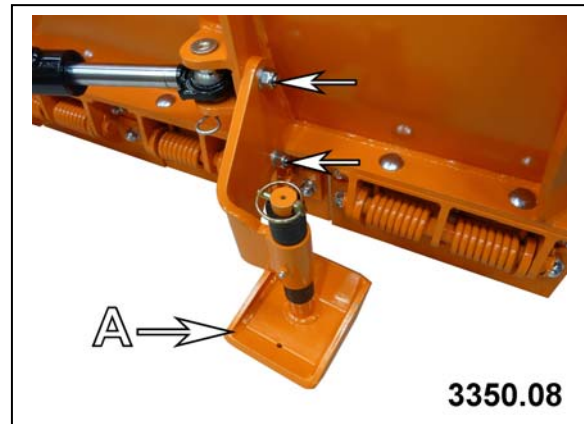

#### 2.3.2. for the model 3359

Screw on skid shoes (A) in the available hole pattern on both sides.

Unhinge the hydraulic cylinder at the share plate to insert the top screw.

The figure shows the skid shoe on the right-hand side.

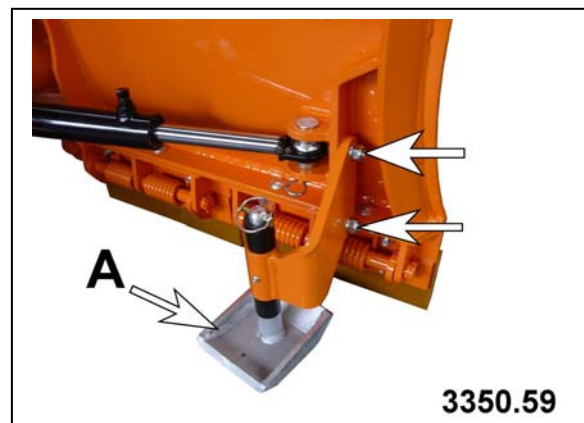

## 2.0. Assembly

### 2.4. Installing the support wheels

#### 2.4.1. for the models 3353 and 3354

Unhinge the hydraulic cylinder at the share plate to insert the top screw.

Screw on support wheels (A) in the available hole pattern on both sides.

The support wheel bracket must be angled inwards as shown in figure 3350.09.

The figure shows the support wheel on the right-hand side.



#### 2.4.2. for model 3355

Unhinge the hydraulic cylinder at the share plate to insert the top screw.

Screw on support wheels (A) in the available hole pattern on both sides.

The wheel bracket is angled outwards, a larger clearance for the 3-point installation is thus achieved.

The figure shows the support wheel on the right-hand side.

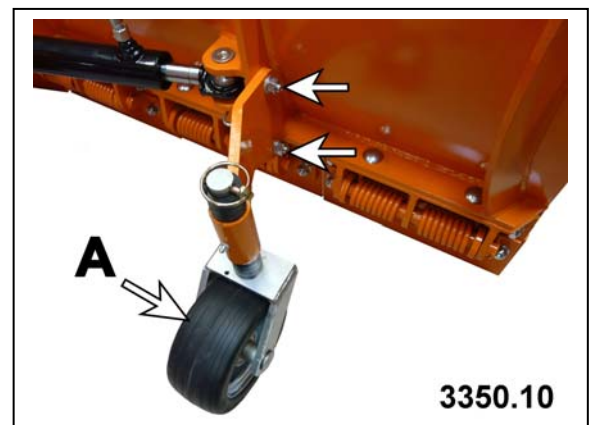

#### 2.4.3. for model 3359

Unhinge the hydraulic cylinder at the share plate to insert the top screw.

Screw on support wheels (A) in the available hole pattern on both sides.

The support wheel bracket must be angled inwards as shown in figure 3350.60.

The figure shows the support wheel on the right-hand side.

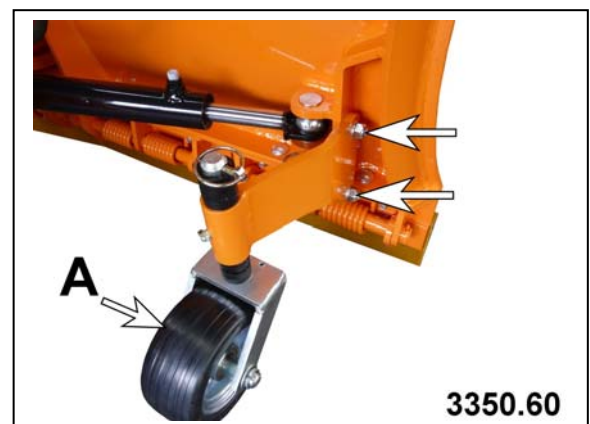

## 2.0. Assembly

### 2.5. Mounting the lighting unit

#### 2.5.1. for the model 3352

Side lamp (A) must be screwed on so that it is inclined outwards.

**NOTE:**

the white light disc must be facing forward in the direction of travel.

The cables must be laid as per figure 3350.12 to bracket (B) and secured using cable ties.

Connect cables in socket (C) according to the enclosed connection diagram.

Screw socket (C) onto bracket (B).

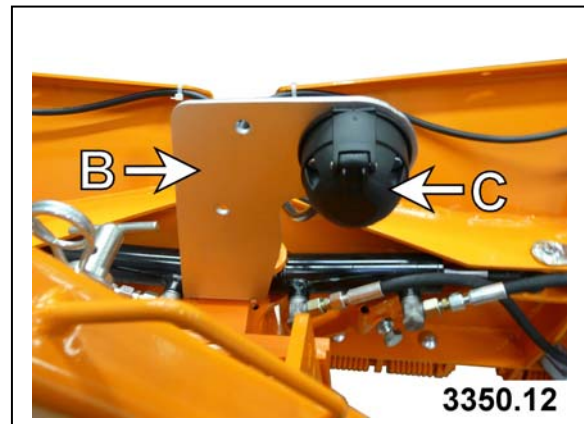
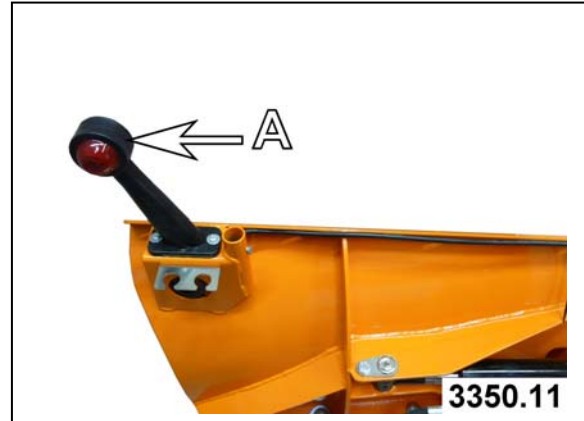

#### 2.5.2. for the models

3353; 3354; 3355 and 3359

Side lamp (A) must be screwed on so that it is inclined outwards.

**NOTE:**

the white light disc must be facing forward in the direction of travel.

The cables must be laid as per figure 3350.14 to bracket (B) and secured using cable ties.

Connect cables in socket (C) according to the enclosed connection diagram.

Screw socket (C) onto bracket (B).

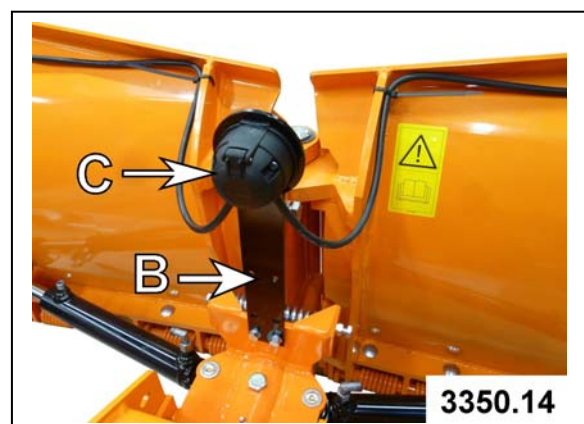
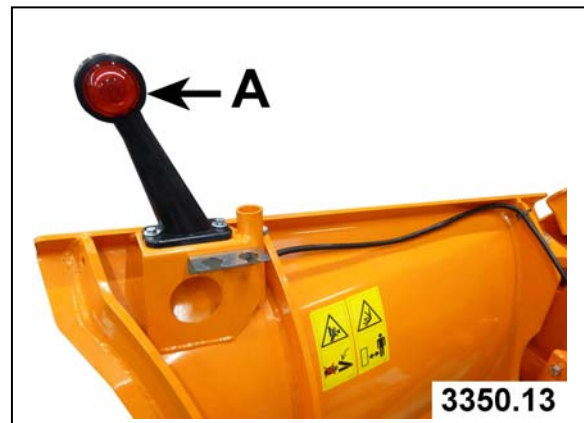

## 2.0. Assembly

### 2.6. Installing the blade adjustment

Only for model 3352 and 3357

Secure control block (A) to bracket (B).

Secure hydraulic hose (C) to rear part of cylinder.

Secure hydraulic hose (D) to front part of cylinder.

Hydraulic hoses (E and F ) are to be connected to the tractor.

Connect the connection cable (G) for the electromagnetic adjustment of the control block to the tractor.

If your tractor is not equipped with such a socket, please consult your dealer or have one installed by a specialist technician.

The loose parts for the installation of a suitable socket are included in the scope of delivery.

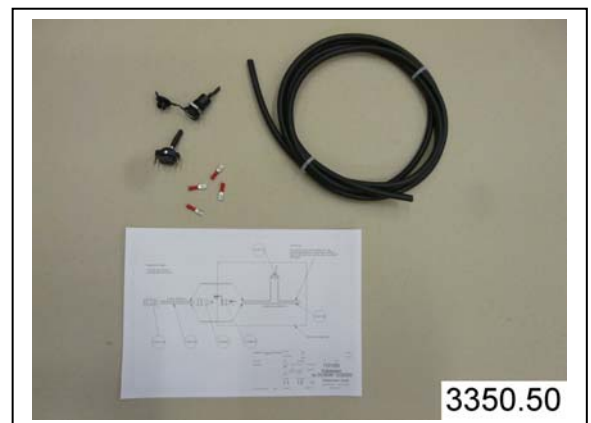
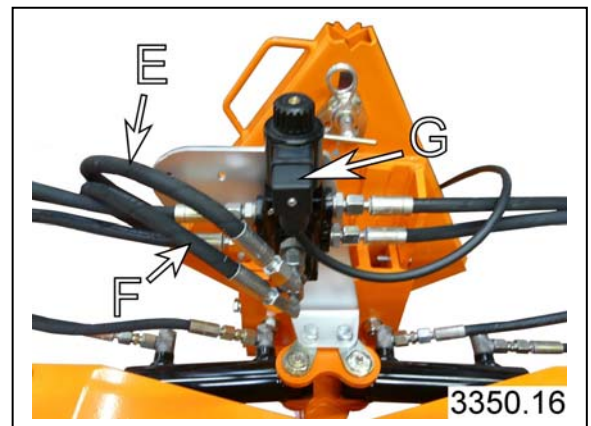
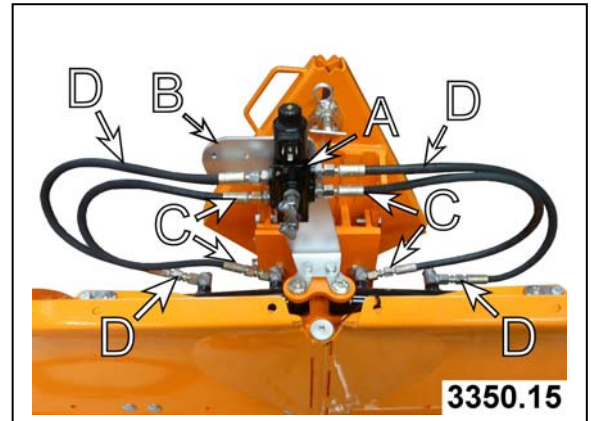



## 2.0. Assembly

### 2.7. Two-fold control block expansion

Only for the models

3353; 3354; 3355 and 3359

Secure control block (A) to bracket (B).

Secure shorter hydraulic hose (C) to rear part of cylinder.

Secure longer hydraulic hose (D) to front part of cylinder.

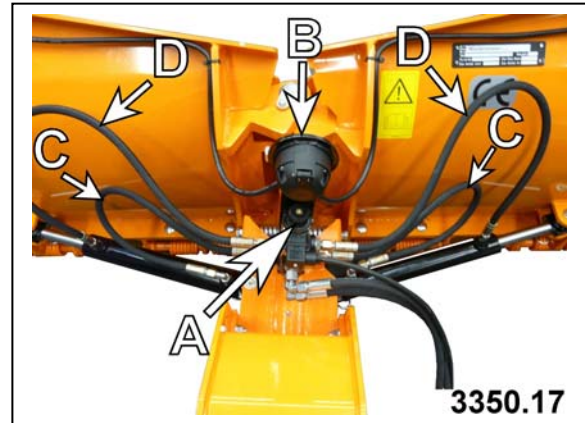

Hoses (E and F ) are to be connected to the tractor.

Connect the connection cable (G) for the electromagnetic adjustment of the control block to the tractor.

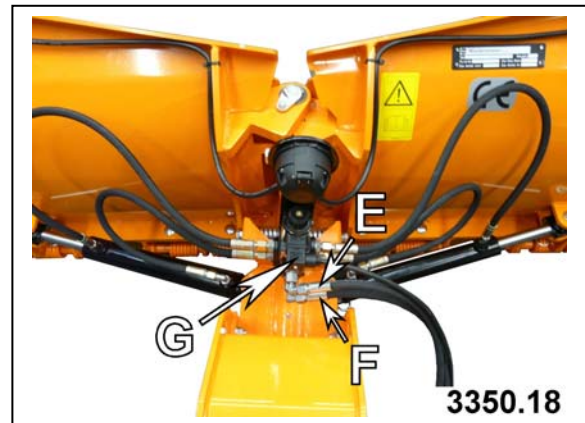

If your tractor is not equipped with such a socket, please consult your dealer or have one installed by a specialist technician.

The loose parts for the installation of a suitable socket are included in the scope of delivery.

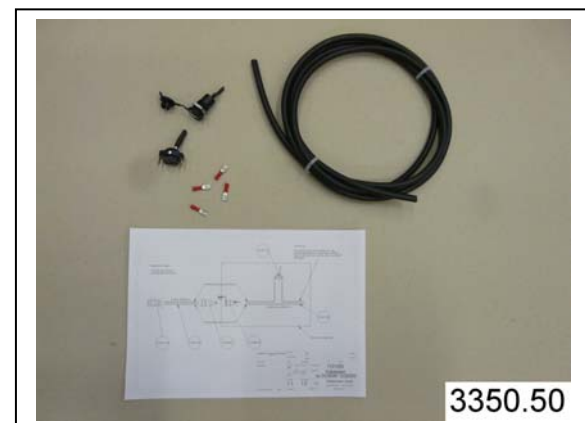



## 3.0. Transport

### 3.1. General Information



#### CAUTION DANGER:

- The SNOW MASTER VARIO is delivered secured to a transport frame.
- Only use fork lifts, cranes or hoisting gear with sufficient lifting capacity.
- Never stand under lifted loads. There is an imminent danger to life if the load falls.

Improper transport and mounting of SNOW MASTER VARIO can result in:

- injury to persons
- damage to property.

Pay special attention to the direction of approach when lifting TERRA SPIKE with the transport frame.

We do not accept any liability for damage resulting from improper handling.

## 3.0. Transport

### 3.2. Transporting the SNOW MASTER VARIO



#### CAUTION DANGER:

Caution must be exercised when cutting through the securing straps. Risk of injury due to ends "springing open".

#### 3.2.1. Transport Using a Forklift

If the SNOW MASTER VARIO is still secured to the transport frame:

- Insert the forks under the transport frame (pay attention to the direction of approach),
- carefully lift the transport frame,
- unload the SNOW MASTER VARIO from the transport device when it is balanced,
- cut through the securing straps,
- connect SNOW MASTER VARIO to the tractor and lift it from the transport frame (See item 4.2.)



#### 3.2.2. Transport Using a Crane

- Only attach the cables or straps to bore (A).
- Unload the SNOW MASTER VARIO when it is securely suspended.

#### NOTE :

Transportation damage and missing parts must be immediately reported in writing to the transport company and Wiedenmann GmbH or the supplier.

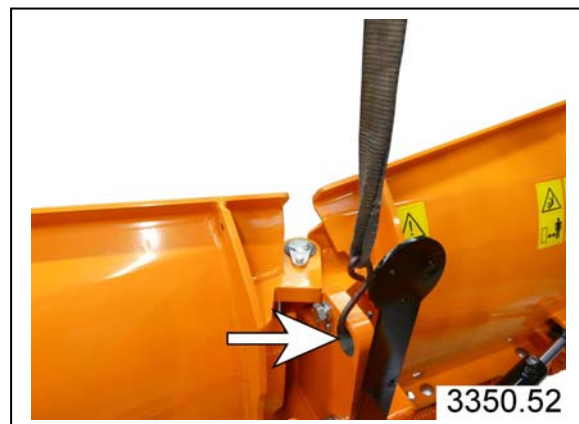

## 3.0. Transport

### 3.3. Transport

#### 3.3.1. with 3-point installation

Raise the attached equipment with the tractor rear hydraulic system and secure against inadvertent lowering.

When driving on public roads, please observe the swivel range of the attached SNOW MASTER VARIO.

#### 3.3.2. with coupling triangle

Raise the attached equipment with the tractor rear hydraulic system and secure against inadvertent lowering.

When driving on public roads, please observe the swivel range of the attached SNOW MASTER VARIO.

## 4.0. Connecting to the Tractor

### 4.1. General Information



#### CAUTION DANGE:

Do not exceed the max. authorized axle load of the tractor.

For this work, please use your personal protective equipment (PSA) such as: gloves, goggles, ear protectors.

### 4.2. The correct position of the installation trestle

The attachment components must be attached to the rake blade so that the lower guide bar of the tractor front hydraulic system are parallel to the ground or just slightly tilted downward.

In working position, the attachment frame should be perpendicular to the floor.

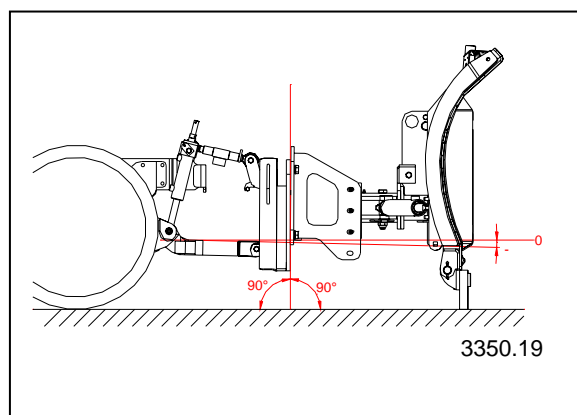

#### P1 Standard position upon delivery

This is the highest position of the adapter plate.

#### Position P2

The adapter plate is screwed on 1 hole lower down.

#### Position P3

The adapter plate is turned downwards through 180 degrees.

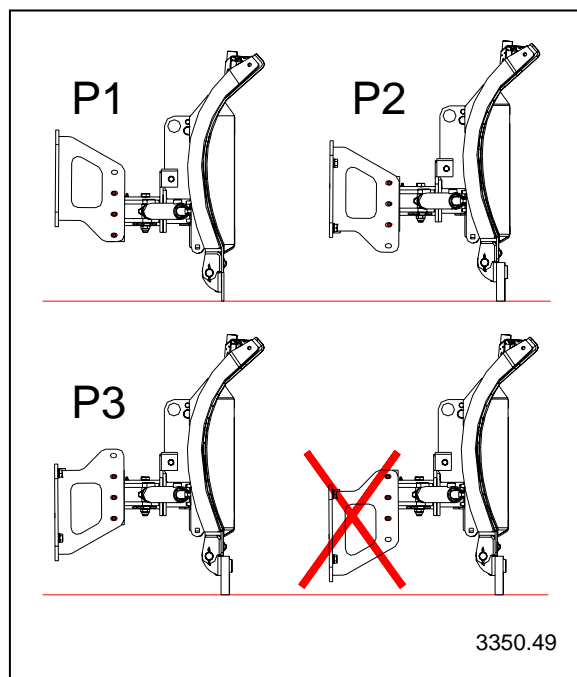

## 4.0. Connecting to the Tractor

### 4.3. Attaching with A-frame cat. 0 A

Carefully drive up to the A-frame cat. 0.

Lift the tractor front hydraulic system so that the A-frame cat. 0 engages.

Adjust safety catch (A) or insert lever screw.

Raise parking supports.

Connect hydraulic lines.

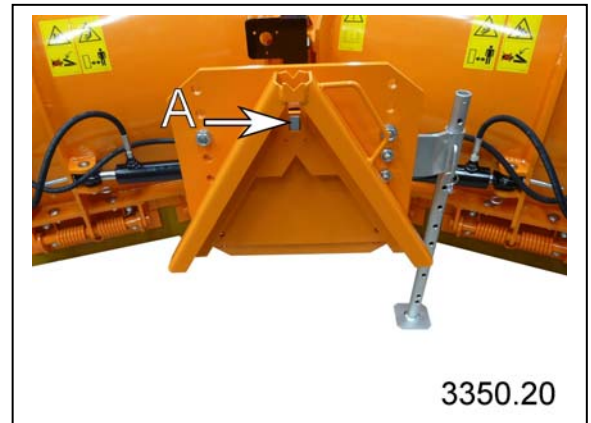

### 4.4. Attaching with triangular coupling B

Carefully drive up to the triangular coupling.

Lift the tractor front hydraulic system so that the triangular coupling engages.

Adjust safety catch (A).

Raise parking supports.

Connect hydraulic lines.

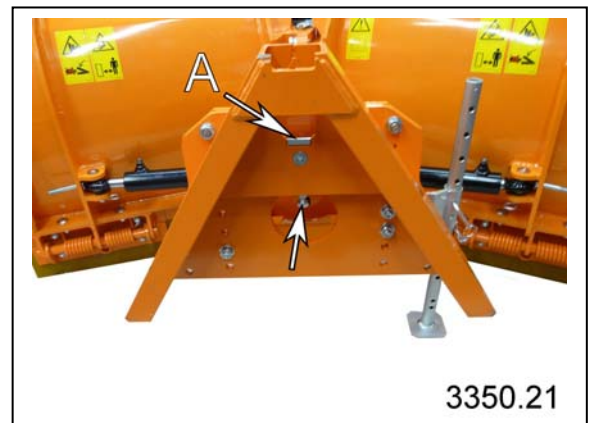

Attachment only permitted for types 3353, 3354 and 3355

## 4.0. Connecting to the Tractor

### 4.5. Attaching with three-point frame C

Carefully navigate between the attachment brackets using the tractor front hydraulic system.

Insert lower guide bar and secure with bolts (A).

Peg out upper guide bar with pin (B) on three-point frame and secure.

Raise parking supports.

Connect hydraulic lines.

Adjust the upper guide bar so that the three-point frame is perpendicular to the road.

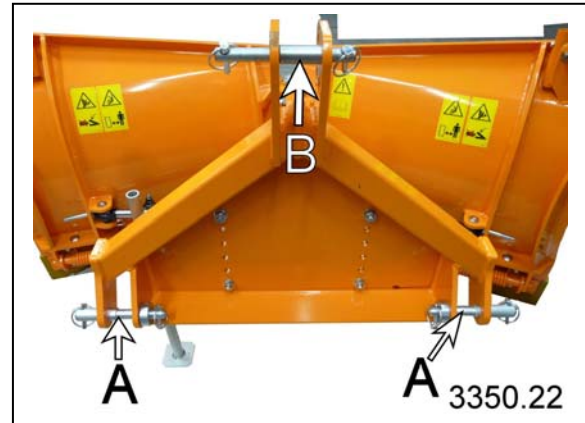

### 4.6. Raising the parking support

When the attachment process is finished, insert and secure the parking support in the topmost position.

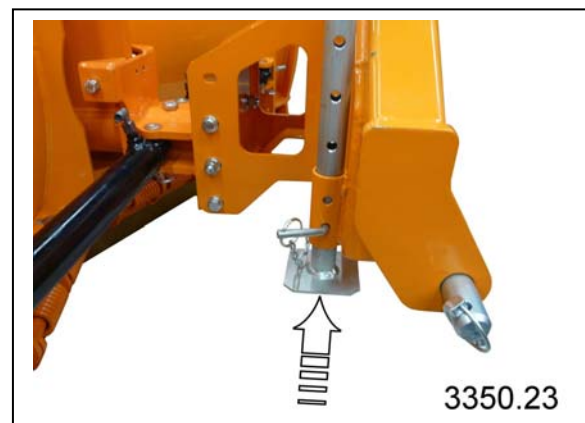



## 4.0. Connecting to the Tractor

### 4.7. Connecting the hydraulic system

The hydraulic system is connected to the hydraulic sockets located on the front of the tractor.

If your tractor is not equipped with such a socket, please contact your dealer.

Avoid tight bends and chafing of the hydraulic lines.

### 4.8. Ballast

When mounting equipment at the front, always ensure there is permissible front axle load; steering must remain supported. Loads must always be attached to the mounting points provided in accordance with regulations.

When selecting the additional weights, ensure that the permissible axle load weight, as well as the permissible overall weight including the mounted equipment, is not exceeded.



**ATTENTION:**  
Specifications in the  
Operating Instructions for  
the tractor must be  
observed.

## 5.0. Disconnecting from the Tractor

### 5.1. General Information



#### CAUTION DANGER:

For all operations the engine must be switched off and the ignition key must be removed.

Secure the tractor against rolling away.

Always park on a paved and even surface when detaching the machine.

For this work, please use your personal protective equipment (PSA) such as: gloves, goggles, ear protectors.

The attachment components are described in section 9.3.

### 5.2. Lowering the support

For removal, the support must be lowered into position, inserted and secured to ensure that the next attachment procedure does not pose any risk and that the Snow Master does not tip over forwards.

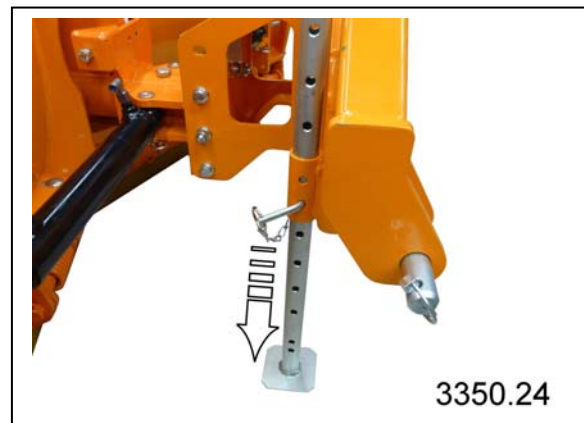

### 5.3. Releasing the hydraulic connection

Disconnect all hydraulic from the tractor.

Hydraulic pipe → attach to the fitted retainer.



## 5.0. Disconnecting from the Tractor

### 5.4. Removal with A-frame cat. 0 A

Position the SNOW MASTER VARIO straight.

Lower the supports.

Release safety catch (A) or remove lever screw.

Disconnect hydraulic lines.

Lower the SNOW MASTER VARIO to the ground and carefully back out.



### 5.5. Removal with triangular coupling B

Position the SNOW MASTER VARIO straight.

Lower the supports.

Release safety catch.

Disconnect hydraulic lines.

Lower the SNOW MASTER VARIO to the ground and carefully back out.



### 5.6. Removal with three-point frame C

Position the SNOW MASTER VARIO straight.

Lower the supports.

Disconnect hydraulic lines.

Lower the SNOW MASTER VARIO to the ground.

Disconnect hydraulic lines.

Release upper guide bar and disconnect pins (A) from three-point frame.

Withdraw lower guide bar bolt.

Carefully back out.

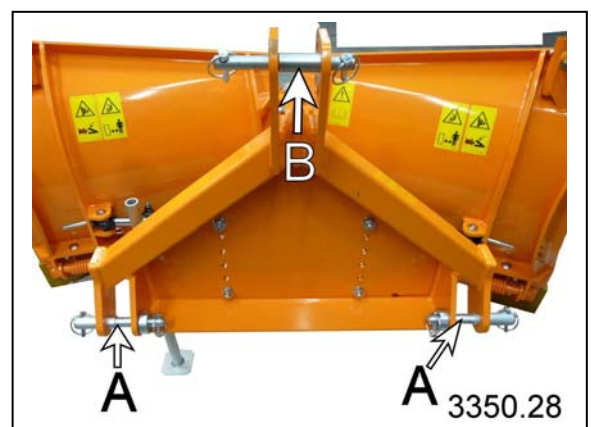

## 6.0. Before Initial Operation

### 6.1. General Information



#### ATTENTION !

Familiarise yourself with all equipment and operating elements and their functions before starting work.

It is too late to do this when you have started work !

In addition to the information provided in these Operating Instructions, please also observe generally applicable safety and accident-prevention standards !

During operation on public highways, the relevant traffic regulations must be observed !

Ensure the permissible front axle load is not exceeded because the steerability of the tractor must be maintained (if necessary, place weights in position as described in the tractor Operating Manual).

Special care should be taken when working and turning on a slope.

**- DANGER OF TOPPLING !**

### 6.2. Adjusting the support wheels

The support wheels must be aligned with the installed scraping rib on an even, firm surface.

Lower the attached rake shield to the ground.

Measure the distance from the support wheels to the ground.

Raise the rake blade in order to be able to refit the spacer rings.

The support wheels can be adjusted downwards in 5 mm steps

by refitting the spacer rings

in the direction **T**

and upwards where the spacer rings are refitted in the direction **H**.

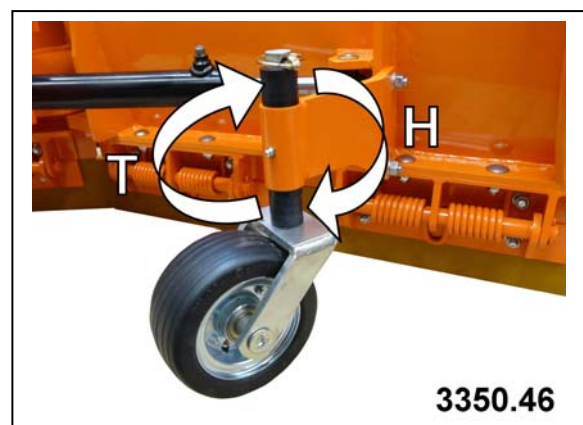

## 6.0. Before Initial Operation

### 6.3. Adjusting the sliding shoes

#### 6.3.1. for the model 3352 and 3357

Align the sliding shoes to the attached scraping edge on a flat, paved surface.

Lower the attached rake shield to the ground.

Release both screws (A).

Align skid shoe (B) with the suitable bore combination and secure using screws (A).

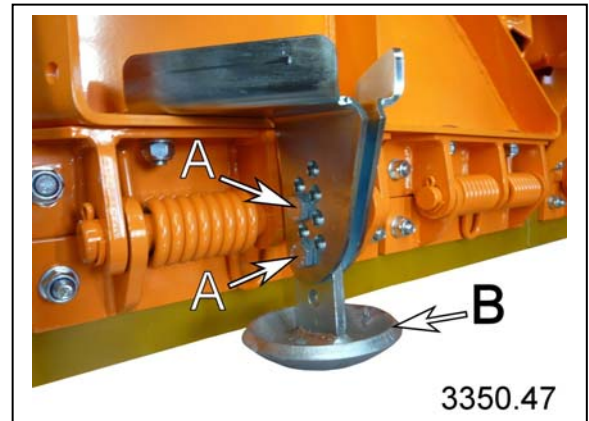

#### 6.3.2. for the models 3353; 3354 and 3355

Align the sliding shoes to the attached scraping edge on a flat, paved surface.

Lower the attached rake shield to the ground.

Measure the distance from the skid shoes to the ground.

Raise the rake blade in order to be able to refit the spacer rings.

The skid shoes can be adjusted downwards in 5 mm steps

by refitting the spacer rings

in the direction **H**

and upwards where the spacer rings are refitted in the direction **T**.

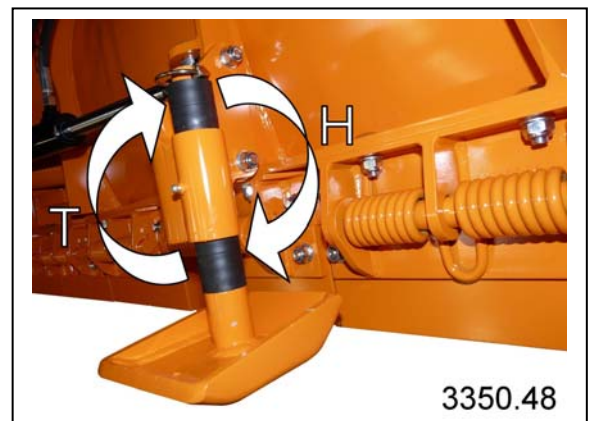

## 7.0. Operation

### 7.1. General Information



#### **ATTENTION !**

The SNOW MASTER VARIO operator is responsible for persons located inside the working area.

Always check the immediate surroundings when starting to drive (Caution - CHILDREN!).

Do not drive backwards when the SNOW MASTER VARIO is operating. Avoid big changes in direction while using yielding tractors.

Fully lift the rake blade in the case of reversing.

The front hydraulics of the tractor must always be in the floating position for operation.

### 7.2. Driving characteristics



#### **ATTENTION !**

- When the **SNOW MASTER VARIO** has been installed, this may have an influence on the driving and operational qualities of the tractor.
- Always adapt your driving style to match the terrain and ground conditions.
- Special care should be taken when working and turning on a slope. - **DANGER OF TOPPLING**
- The operating speed is to be adhered to according to the technical data.

A better result is obtained at low speeds.



## 7.0. Operation

### 7.3. Working with the Snow Master Vario



#### ATTENTION !

In the working area, the user is responsible for the safety of other persons !

The steering lever for the tractor front hydraulic system must principally be in floating position for operation.

Pay attention to the swivel range of the rake shield when working.

Check the joints between tractor and rake shield regularly.

Fully lift the rake blade in the case of reversing.

### 7.4. Malfunctions and troubleshooting

Description	Cause	Remedy
Spring flaps actuate too quickly	Leg spring is fatigued	Replace spring flap
	Leg spring is broken	
Rake shield no longer fits the ground on the sides	Guide is running dry	Lubricate guide surfaces
	Adjusting screws tightened too tightly	Readjust screws
The tractor front wheels are not sufficiently weighed down, resulting in steering problems	Check the position of the control lever for the tractor front hydraulic system	Control lever must be in floating position
	Installation trestle mounted incorrectly	Check the position of the installation trestle and change, if necessary (see Section 4.2.)
Rake shield is rattling severely	Skid shoe incorrectly adjusted	Readjust skid shoes
		Fine-tune the upper guide bar
	Check limit stop and oscillating unit screws	Tighten loose screws

## 8.0. Maintenance

### 8.1. General Information



#### CAUTION DANGER :

**Only qualified personnel are permitted to perform maintenance, repair and disassembly tasks.**

**Only perform maintenance work when the device is attached. Turn off the tractor and secure it against being unintentionally switched on.**

#### CAUTION !

**The springs of the spring flaps are under tension.**

For this work, please use your personal protective equipment (PSA) such as: gloves, goggles, ear protectors.

Use **only original parts**. Third-party parts often do not match the required quality and thus endanger your safety. Moreover, the sustained warranty and recognition of justified warranty claims can only be guaranteed, if you exclusively use **original parts from Wiedenmann**.

We expressly point out to you that non-original parts that have not been delivered by Wiedenmann also have not been approved and released by Wiedenmann. The installation and/or use of such products may actually have a negative impact on the constructional properties of your vehicle and thus may affect the active and/or passive safety.

Damages arising from the use of non-original parts are excluded from the scope of the manufacturer's liability.

After maintenance, remove all parts that do not belong to the SNOW MASTER VARIO.

## 8.0. Maintenance

### 8.2. Maintenance and inspection list

Working hours	Check	Procedure
<b>50</b>	the central pivot point	Lubricate
<b>50</b>	Check skid shoes for wear	Perform sight check, replace worn skid shoes

## 8.0. Maintenance

### 8.3. Lubrication

- Switch "OFF" the engine for all lubrication work.
- Lubricate more often, if required, (until all lubrication points are sufficiently lubricated).
- Clean lubrication nipple before use.
- Clean up leaking grease.
- Before starting the machine after a longer standstill, lubricate and maintain the entire machine
- Keep all exposed machine parts, threaded spindles and guides slightly lubricated.

### Points for manual lubrication

Centre pivotal point and bearing bolts of the hydraulic cylinders

Model 3352

Model 3357

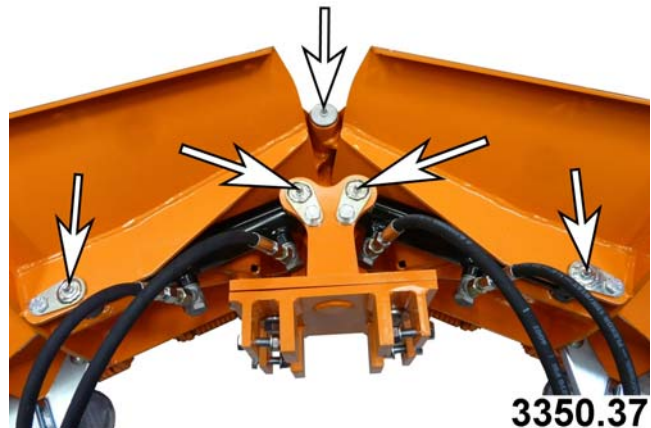

Centre pivotal point

Model 3353

Model 3354

Model 3355

Model 3359

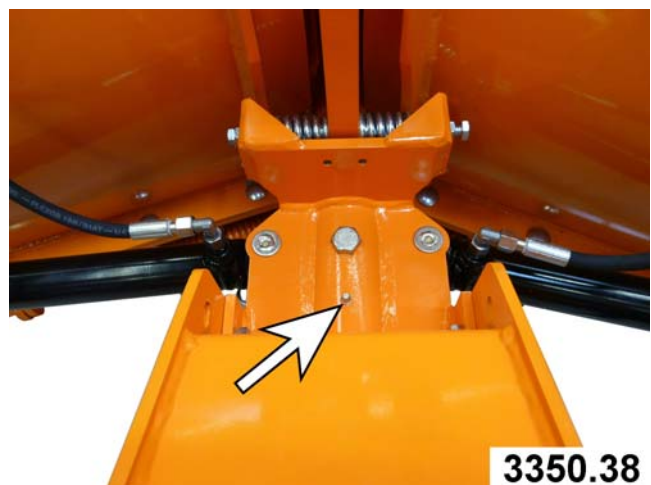

## 8.0. Maintenance

### 8.4. Cleaning

Clean the SNOW MASTER VARIO regularly. You will prolong the service life of expensive components and simultaneously detect:

- Loose components
- Damaged cables or lines
- Wear and unintended collision points.

**NOTE:**

**Do not bring plastic and sealing elements in contact with aggressive fluids (e.g. carbon tetrachloride, tri, benzene, caustic solutions, acids etc.).**

**Bind drops of oil with a binding agent and dispose of it according to the regulations. Eliminate the cause.**

**Only use wire brush and caustic solutions in case of emergency.**

#### Auxiliaries and application

##### Cleaning with water

- All dirty parts, but use caution:  
⇒ water causes rust.

##### Cleaning with dry cloth

- All signs and inscriptions

##### Cleaning with compressed air



**ATTENTION !**

**Exercise caution when using compressed air. Put on safety glasses! Without safety glasses you risk eye injuries! Furthermore you blow dirt into the guides and bearings. For this reason, avoid this cleaning method.**



## 8.0. Maintenance

### 8.5. Care and maintenance of the hydraulic system

Suitable for hydraulic fluids based on mineral, glycol and synthetic oils.

Examine hydraulic hose lines regularly for damage and ageing and replace if necessary

According to the manufacturer's specifications, the replacement period for hydraulic lines is 6 years.



**CAUTION !**

**The hydraulic system is not approved for the use of BIO oils !**



**CAUTION !**

High-pressure fluids leaking under high pressure can penetrate the skin, causing serious injury. For this reason, depressurise the system before disconnecting lines. Before building up pressure in the system again, ensure that all line connections are leak-tight. It is difficult to see hydraulic oil leaking from a small opening. For this reason, use a piece of cardboard when searching for leaks. Protect the hands and body from high-pressure fluids.

If a fluid has penetrated the skin, this must be removed immediately by a doctor familiar with this type of injury; otherwise serious infections are possible. Doctors who are unfamiliar with this type of injury should obtain the relevant information from a competent medical source.

## 8.0. Maintenance

### 8.6. Hydraulic connection diagram

8.6.1. Standard version for  
model 3352 and 3357

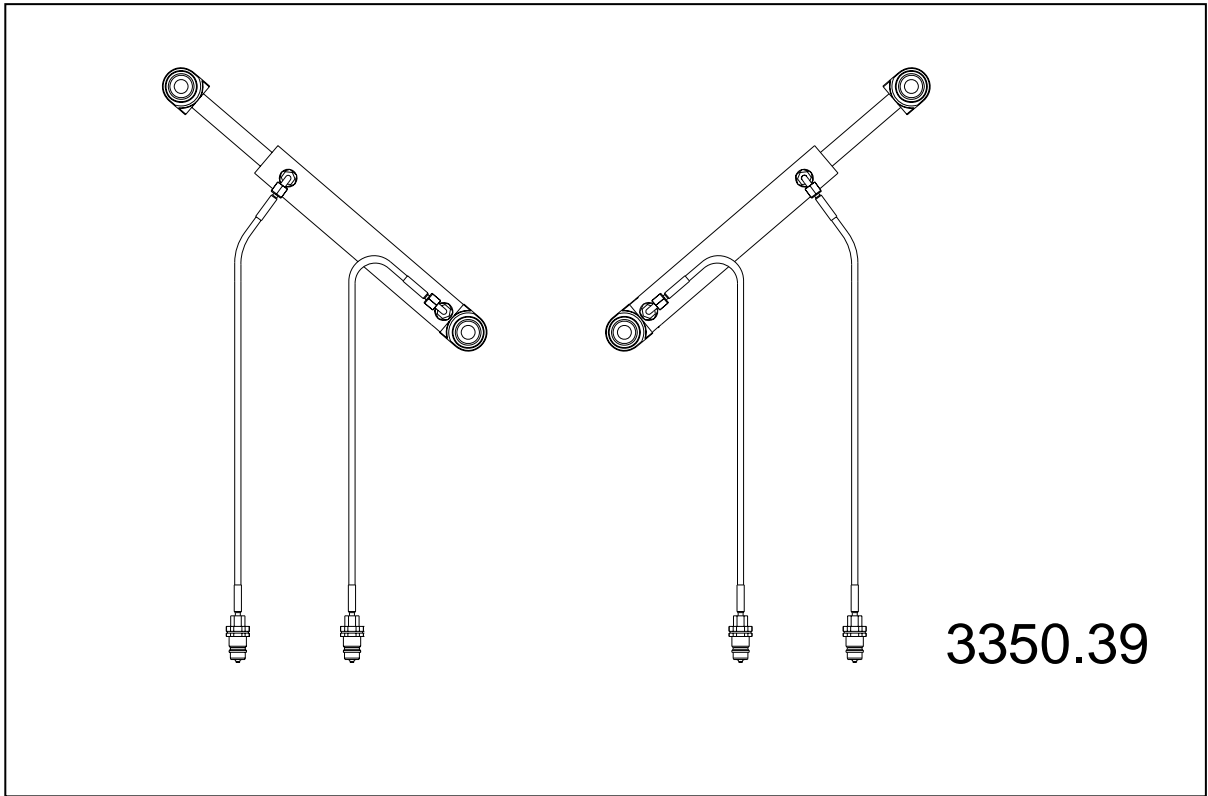

8.6.2. with electromagnetic adjustment  
for MODEL 3352 and 3357

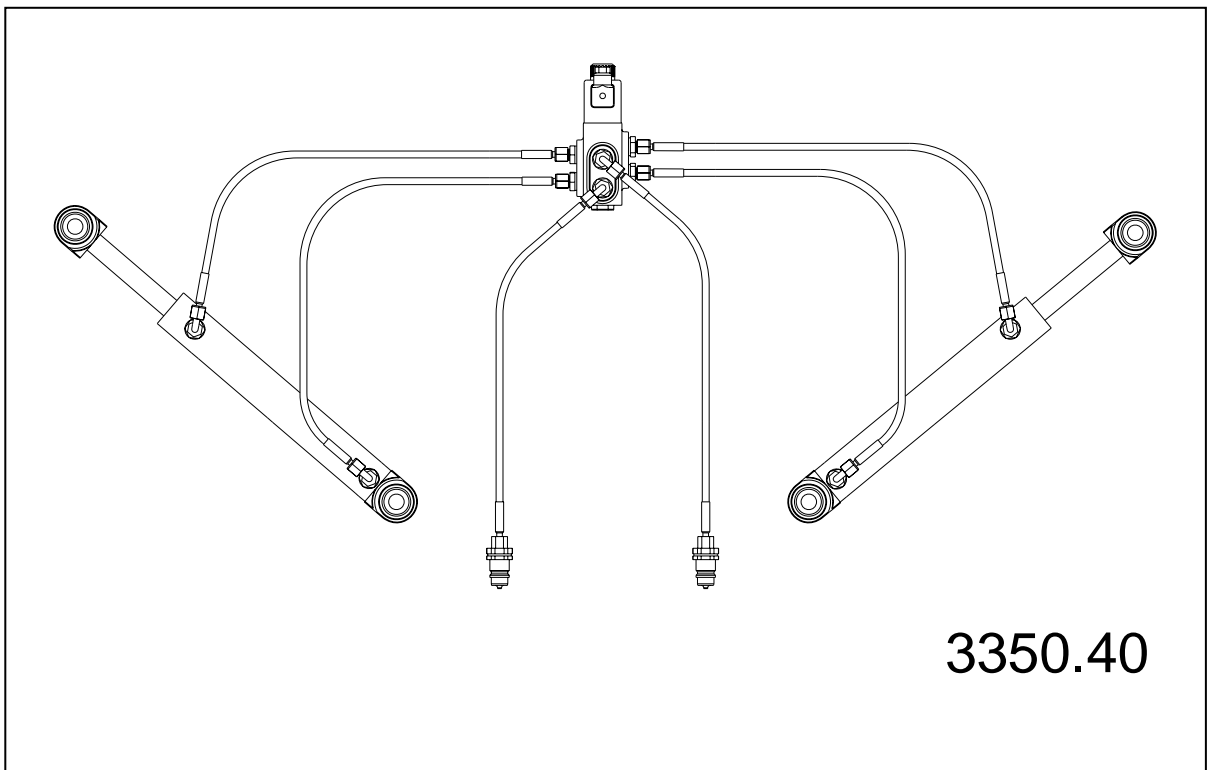



## 8.0. Maintenance

### 8.6. Hydraulic connection diagram

8.6.3. Standard version for the models  
3353; 3354; 3355; 3359

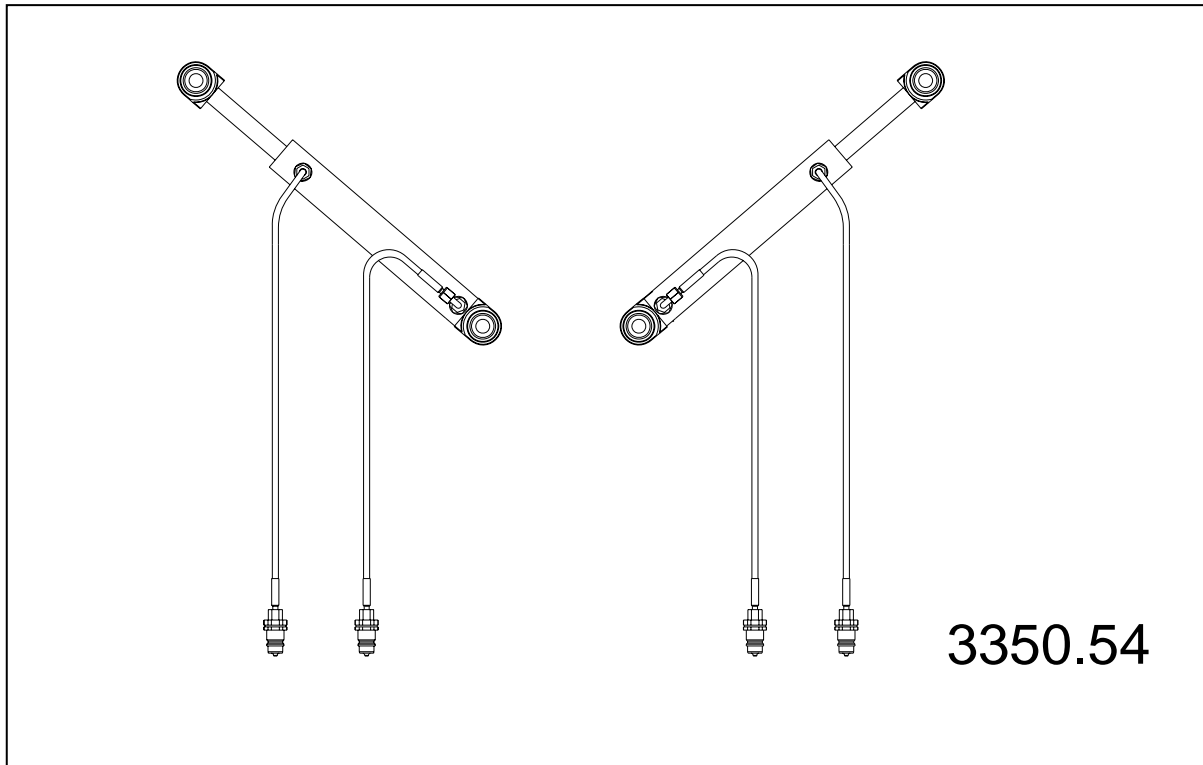

8.6.4. with electromagnetic  
adjustment for the models  
3353; 3354; 3355; 3359

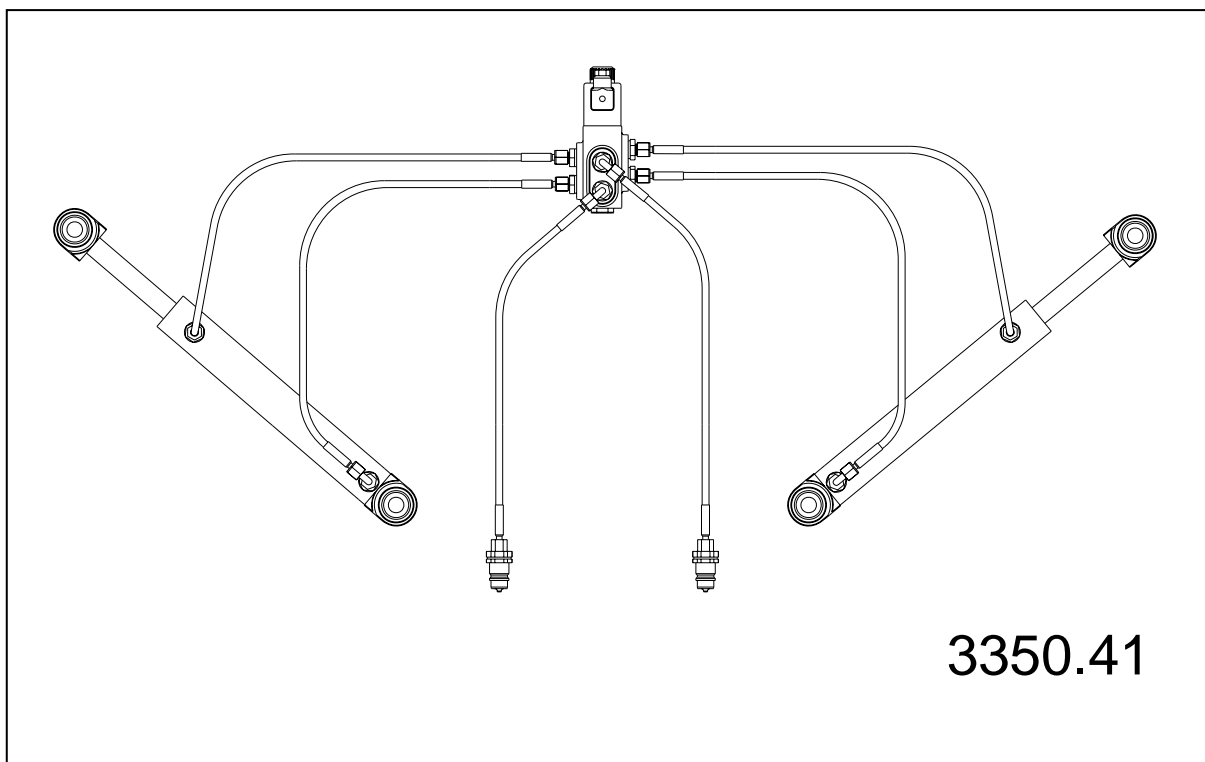

## 8.0. Maintenance

### 8.7. Disassembly / Disposal



#### **ATTENTION !**

Exercise caution when disassembling the SNOW MASTER VARIO. Please refer to the chapter "Safety measures" and local safety regulations.

#### **IMPORTANT**

Specifications and laws concerning the disposal of hazardous substances and pollutants must be observed in all cases. Familiarize yourself completely with the procedure for disposal.

#### **The dangers are as follows:**

- residual pressure in lines and components,
- heavy parts might fall down after being disconnected,
- Tensioned springs
- sharp edges,
- the machine might tilt and crush someone.

#### **Disassembly for disposal**

1. Set the SNOW MASTER VARIO down on stable ground.
2. Drain hydraulic oil.
3. Disassemble SNOW MASTER VARIO from the top downwards.

### 8.8. Unauthorised modification and spare part manufacturing

- Conversions or modifications to SNOW MASTER VARIO are only authorised with the agreement of the manufacturer!
- Original spare parts and accessories authorised by the manufacturer guarantee your safety. The use of other parts might change the characteristics of the SNOW MASTER VARIO. We accept no liability for consequences which occur for this reason.

## 9.0. Additional Equipment

### 9.1. Scope of Delivery

Basic unit

for 3-point installation  
or  
triangular coupling

Hydraulic  
swivel device

Skid shoe fittings  
or  
support wheel fittings

Plastic scraping edge  
or  
steel scraping edge

Operating instructions,  
transfer declaration with  
guarantee card.

### 9.2. Tines Set

	Typ 3352	Typ 3357	Typ 3353	Typ 3354	Typ 3355	Typ 3359
Steel scraping edge	W	W	W	W	W	W
Plastic scraping edge	W	W	W	W	W	W

<b>S = Standard</b>	<b>W = selective</b>	<b>O = optional</b>
---------------------	----------------------	---------------------

## 9.0. Additional Equipment

### 9.3.1. Attachment components for Typ 3352 and 3357

Model **A2**  
A-frame cat. 0

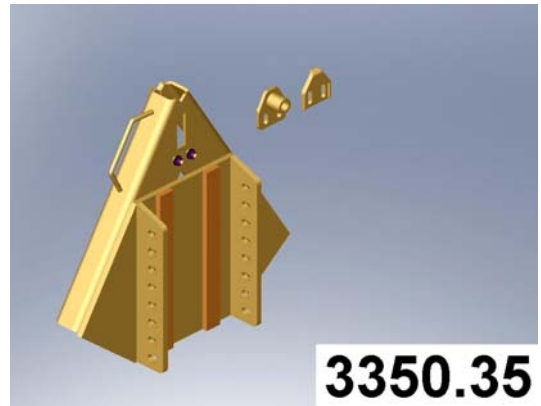

Model **C2**  
three-point hitch cat.1

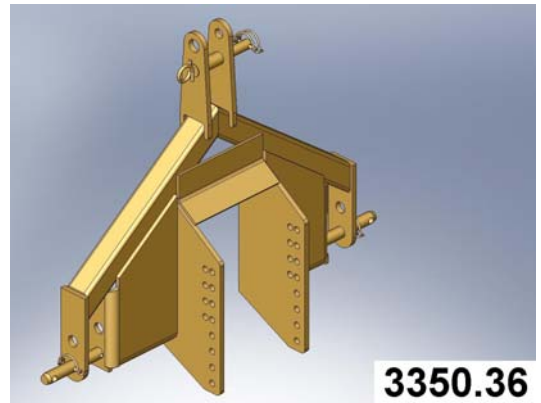

Model **H2**  
for Kärcher MC 50

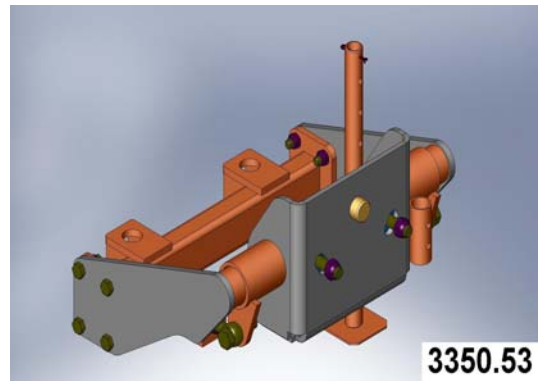

## 9.0. Additional Equipment

### 9.3.2. Standard attachment components for Typ 3353; 3354; 3355; 3359

Model **A**  
A-frame cat. 0

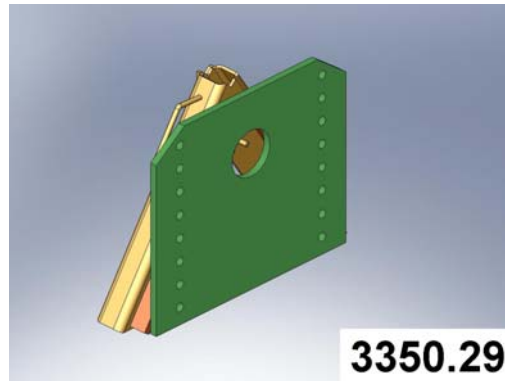

Model **B**  
triangular coupling

Attachment only permitted for  
types 3353, 3354 and 3355

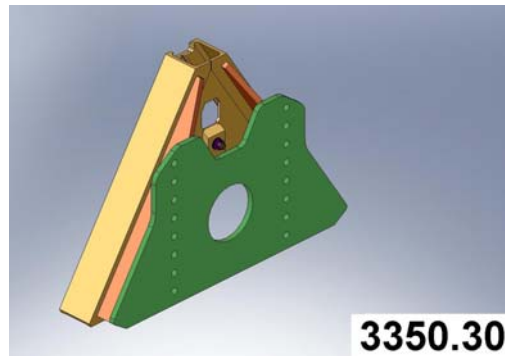

Model **C**  
three-point hitch cat.1

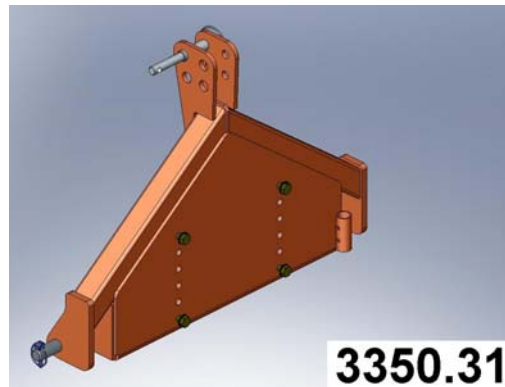

## 9.0. Additional Equipment

### 9.3.2. Special attachment components for Type 3353; 3354; 3355; 3359

Model **D**  
for John Deere tractors  
Type F14XX  
Type F15XX

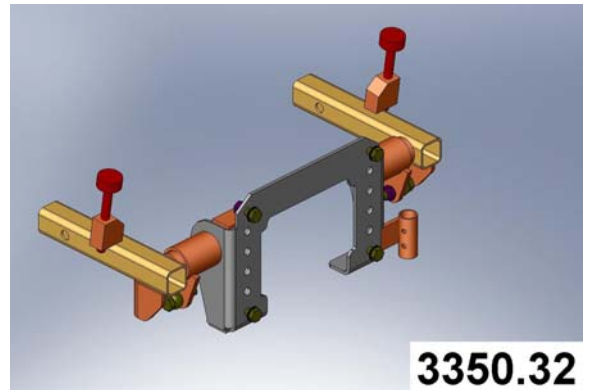

Model **E**  
for Kubota tractors  
Type F25  
Type F30  
Type F3560  
Type F3680

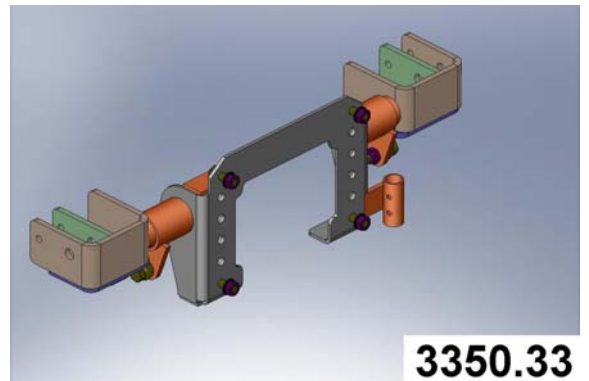

Model **F**  
for Iseki tractors  
Type SF 300  
Type SF 330

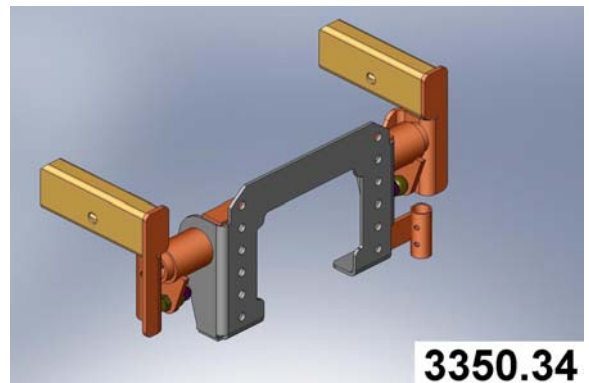

Model **G**  
for New Holland tractors  
Type MC 35  
for Shibaura tractors  
Type CM 364

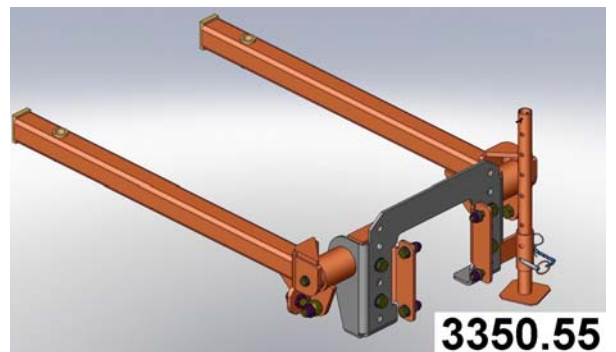

## 9.0. Additional Equipment

### 9.3.2. Special attachment components for Type 3353; 3354; 3355; 3359

Model **H**  
for Holder tractors  
Type Multiprk

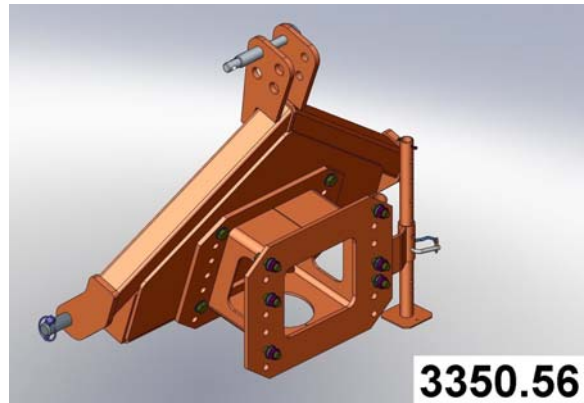

Model **J**

Standard adapter

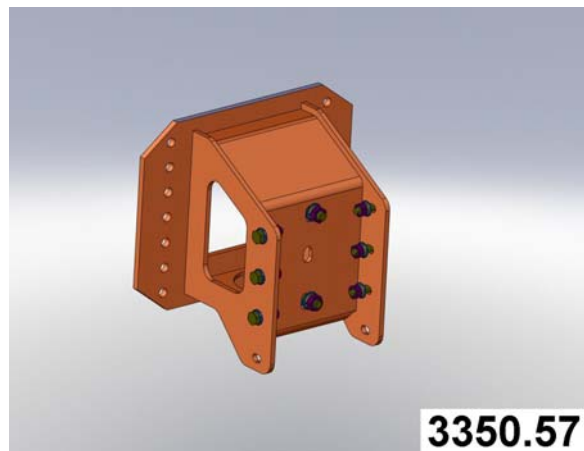

Short adapter

Attachment depends on the working width and the use of a skid shoe or support wheel

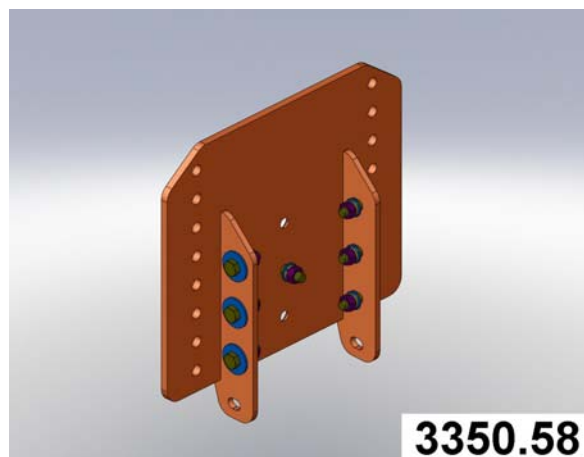

## 9.0. Additional Equipment

### 9.4. Special equipment

	Typ 3352	Typ 3357	Typ 3353	Typ 3354	Typ 3355	Typ 3359
Skid shoe fittings	<b>S</b>	<b>S</b>	<b>W</b>	<b>W</b>	<b>W</b>	<b>W</b>
Support wheel fittings	- - -	- - -	<b>W</b>	<b>W</b>	<b>W</b>	<b>W</b>
Side lamp fittings	<b>O</b>	- - -	<b>O</b>	<b>O</b>	<b>O</b>	<b>O</b>
Two-fold control block expansion	- - -	- - -	<b>O</b>	<b>O</b>	<b>O</b>	<b>O</b>
Warning flag fittings	<b>O</b>	- - -	<b>O</b>	<b>O</b>	<b>O</b>	<b>O</b>
Electromagnetic blade adjustment	<b>O</b>	<b>O</b>	- - -	- - -	- - -	- - -

<b>S = standard</b>	<b>W = selective</b>	<b>O = optional</b>
---------------------	----------------------	---------------------



## 10.0. Technical Specifications

### 10.1. Technical Data Type 3352 and 3357

		Typ	3352	3357
<b>A</b>	Effective width in straight position	mm	1380	1110
<b>B</b>	Effective width in inclined position	mm	1210	990
<b>C</b>	Working width in wedge position	mm	1200	975
<b>D</b>	Working width in V-position	mm	1260	970
<b>E</b>	Width of device	mm	1460	1190
<b>F</b>	Height of device	mm	635	620
<b>F1</b>	Machine height with side lamps	mm	795	- - -
<b>F2</b>	Height of device incl. attachment C	mm	815	815
<b>G</b>	Shield height	mm	610	590
	Length of device of device from tractor connecting point :			
<b>H</b>	Basic unit without attachment components	mm	370	360
<b>H1</b>	Basic unit with attachment A2	mm	440	430
<b>H2</b>	Basic unit with attachment B2	mm	490	480
	Working speed at full weight loads on jockey wheels or slide shoes	km/h	20	20
	Working speed at full weight loads on wear strips	km/h	8	8
	Attachment to vehicles up to	KW (PS)	19 (25)	19 (25)
	Max. hydraulic operating pressure	bar	175	175
	Weights:			
	Basic unit	kg	100	90
	Attachment components – A2	kg	17	17
	Attachment components – C2	kg	25	25
	Attachment components – H2	kg	25	25
	Attachment – steel scraping edges	kg	13	11
	Attachment – plastic scraping edges	kg	8	6
	Attachment – set of lights	kg	2	0
	Attachment – electromagnetic blade adjustment	kg	6	6
	Attachment – two-fold control block	kg	5	5
	Max. total weight	kg	146	132

# 10.0. Technical Specifications

## 10.1. Technical Data Type 3352 and 3357

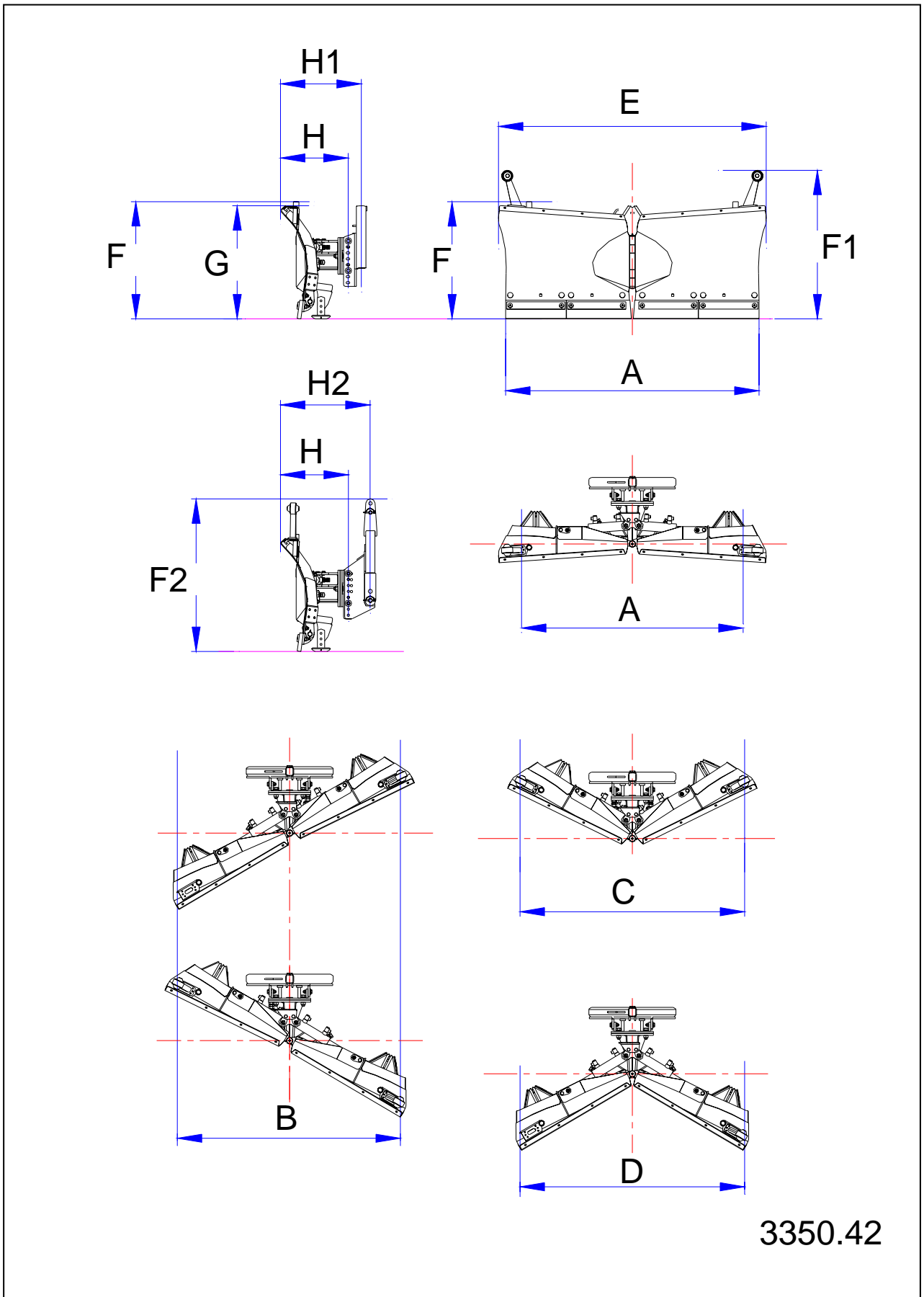

## 10.0. Technical Specifications

### 10.2. Technical Data Series 3350

		Type	3359	3353
<b>A</b>	Effective width in straight position	mm	1505	1670
<b>B</b>	Effective width in inclined position	mm	1325	1460
<b>C</b>	Working width in wedge position	mm	1370	1480
<b>D</b>	Working width in V-position	mm	1310	1450
<b>E</b>	Width of device	mm	1505	1740
<b>F</b>	Height of device	mm	795	810
<b>F1</b>	Machine height with side lamps	mm	965	975
<b>F2</b>	Height of device incl. attachment C	mm	845	845
<b>G</b>	Shield height	mm	775	805
	Length of device of device from tractor connecting point :			
<b>H</b>	Basic unit without attachment components	mm	615	615
<b>H1</b>	Basic unit with attachment A	mm	685	685
<b>H2</b>	Basic unit with attachment B	mm	705	705
<b>H3</b>	Basic unit with attachment C	mm	715	715
	Working speed at full weight loads on jockey wheels or slide shoes	Km/h	20	20
	Working speed at full weight loads on wear strips	Km/h	8	8
	Attachment to vehicles up to	KW (PS)	60 (80)	60 (80)
	Max. hydraulic operating pressure	bar	175	175
	Weights:			
	Basic unit	kg	154	172
	Attachment components – A	kg	20	20
	Attachment components – B	kg	30	30
	Attachment components – C	kg	34	34
	Attachment components – D	kg	17	17
	Attachment components – E	kg	20	20
	Attachment components – F	kg	17	17
	Attachment – steel scraping edges	kg	20	20
	Attachment – plastic scraping edges	kg	10	10
	Attachment – electromagnetic blade adjustment	kg	12	12
	Attachment – support wheel fittings	kg	19	19
	Attachment – set of lights	kg	2	2
	Max. total weight	kg	250	262

# 10.0. Technical Specifications

## 10.2. Technical Data Series 3350

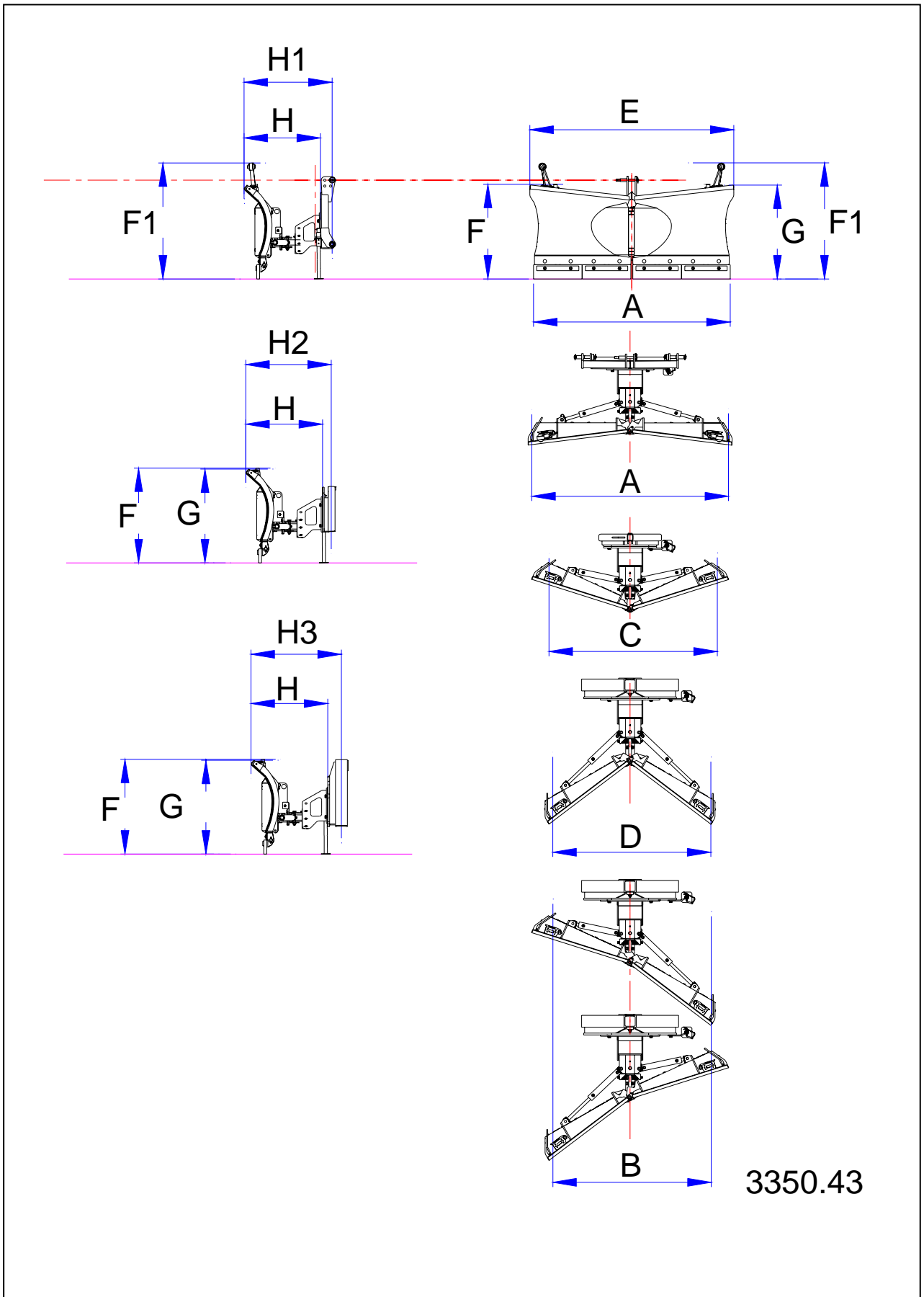

## 10.0. Technical Specifications

### 10.3. Technical Data Series 3350

		Type	3354	3355
<b>A</b>	Effective width in straight position	mm	1860	2000
<b>B</b>	Effective width in inclined position	mm	1640	1750
<b>C</b>	Working width in wedge position	mm	1680	1790
<b>D</b>	Working width in V-position	mm	1600	1720
<b>E</b>	Width of device	mm	1870	2045
<b>F</b>	Height of device	mm	810	820
<b>F1</b>	Machine height with side lamps	mm	985	985
<b>F2</b>	Height of device incl. attachment C	mm	845	845
<b>G</b>	Shield height	mm	810	810
	Length of device of device from tractor connecting point :			
<b>H</b>	Basic unit without attachment components	mm	655	665
<b>H1</b>	Basic unit with attachment A	mm	725	735
<b>H2</b>	Basic unit with attachment B	mm	745	755
<b>H3</b>	Basic unit with attachment C	mm	755	765
	Working speed at full weight loads on jockey wheels or slide shoes	Km/h	20	20
	Working speed at full weight loads on wear strips	Km/h	8	8
	Attachment to vehicles up to	KW (PS)	60 (80)	60 (80)
	Max. hydraulic operating pressure	bar	175	175
	Weights:			
	Basic unit	kg	180	198
	Attachment components – A	kg	20	20
	Attachment components – B	kg	30	30
	Attachment components – C	kg	34	34
	Attachment components – D	kg	17	17
	Attachment components – E	kg	20	20
	Attachment components – F	kg	17	17
	Attachment – steel scraping edges	kg	23	23
	Attachment – plastic scraping edges	kg	13	13
	Attachment – electromagnetic blade adjustment	kg	12	12
	Attachment – support wheel fittings	kg	19	19
	Attachment – set of lights	kg	2	2
	Max. total weight	kg	275	282

# 10.0. Technical Specifications

## 10.3. Technical Data Series 3350

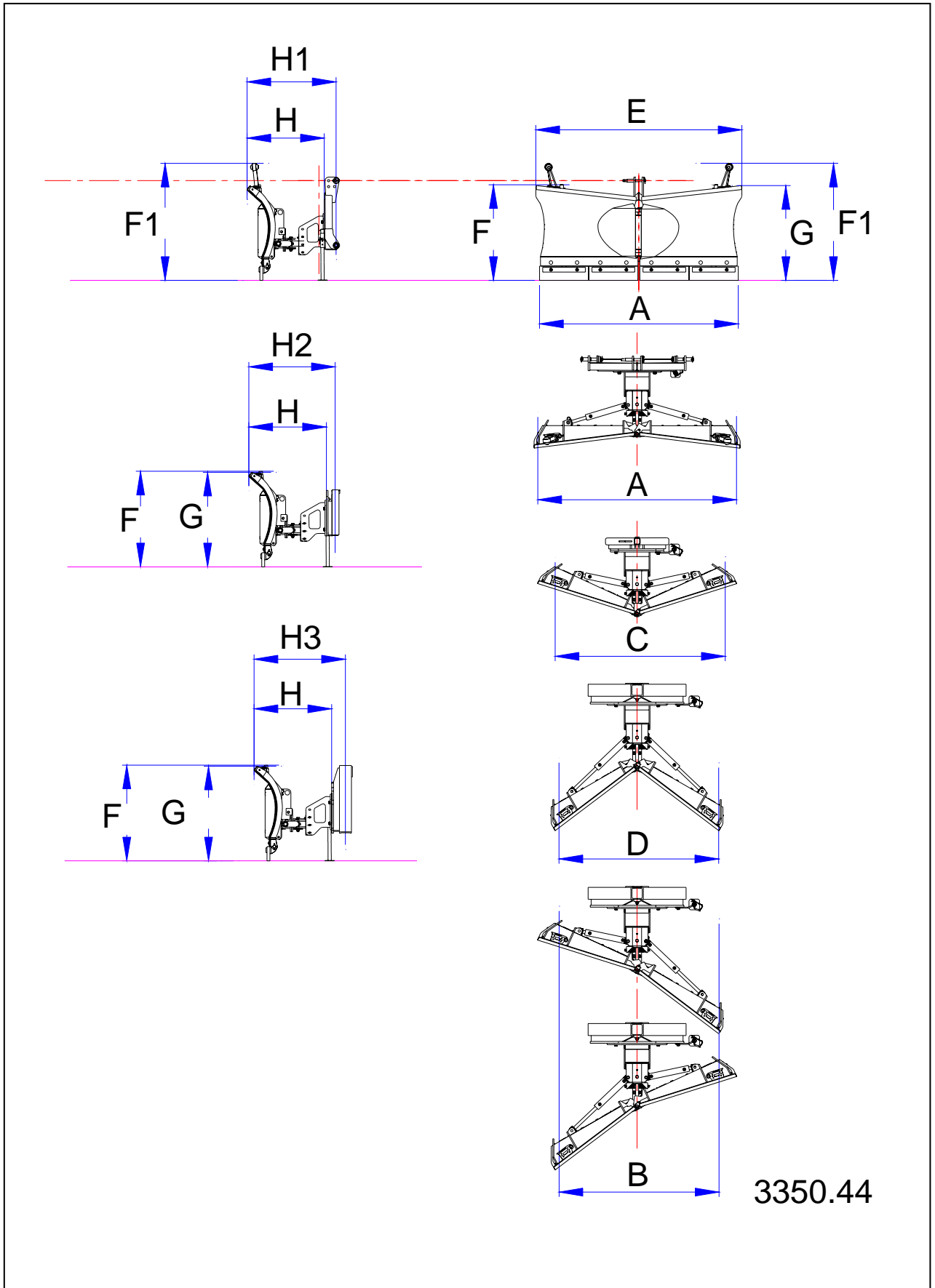

# 10.0. Technical Specifications

## 10.4. Metric bolt and cap screw torque values

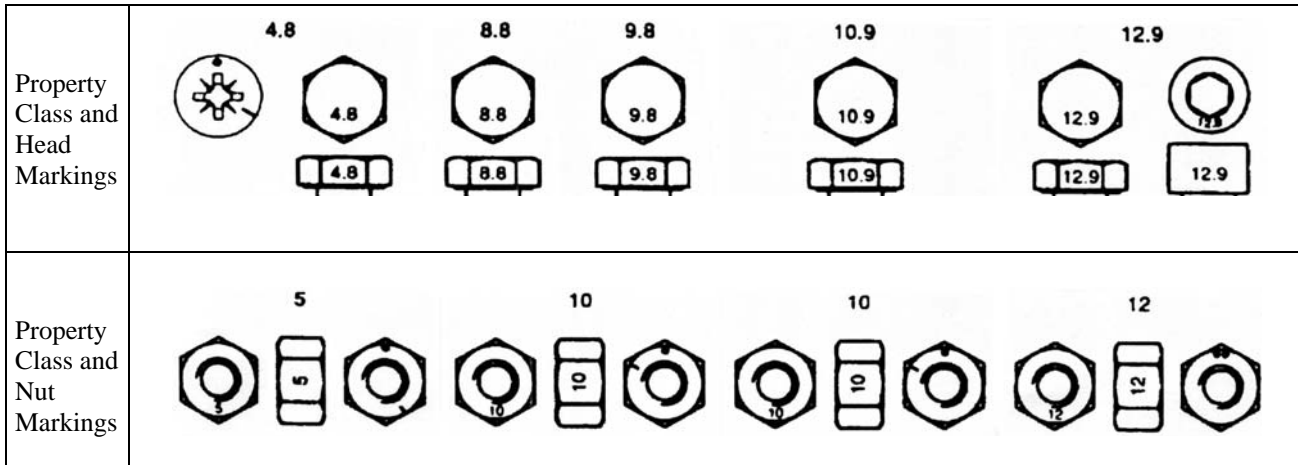

Size	class 4.8				class 8.8 or 9.8				class 10.9				class 12.9			
	Lubricated *		Dry **		Lubricated *		Dry **		Lubricated *		Dry **		Lubricated *		Dry **	
	N-m	lb-ft	N-m	lb-ft	N-m	lb-ft	N-m	lb-ft	N-m	lb-ft	N-m	lb-ft	N-m	lb-ft	N-m	lb-ft
M6	4,8	3,5	6	4,5	9	6,5	11	8,5	13	9,5	17	12	15	11,5	19	14,5
M8	12	8,5	15	11	22	16	28	20	32	24	40	30	37	28	47	35
M10	23	17	29	21	43	32	55	40	63	47	80	60	75	55	95	70

M12	40	29	50	37	75	55	95	70	110	80	140	105	130	95	165	120
M14	63	47	80	60	120	88	150	110	175	130	225	165	205	150	260	190
M16	100	73	125	92	190	140	240	175	275	200	350	255	320	240	400	300

M18	135	100	175	125	260	195	330	250	375	275	475	350	440	325	560	410
M20	190	140	240	180	375	275	475	350	530	400	675	500	625	460	800	580
M22	260	190	330	250	510	375	650	475	725	540	925	675	850	625	1075	800

M24	330	250	425	310	650	475	825	600	925	675	1150	850	1075	800	1350	1000
M27	490	360	625	450	950	700	1200	875	1350	1000	1700	1250	1600	1150	2000	1500
M30	675	490	850	625	1300	950	1650	1200	1850	1350	2300	1700	2150	1600	2700	2000

M33	900	675	1150	850	1750	1300	2200	1650	2500	1850	3150	2350	2900	2150	3700	2750
M36	1150	850	1450	1075	2250	1650	2850	2100	3200	2350	4050	3000	3750	2750	4750	3500

DO NOT use these values if a different torque value or tightening procedure is given for a specific application. Torque values listed are for general use only. Check tightness of fasteners periodically.

Shear bolts are designed to fail under predetermined loads. Always replace shear bolt with identical property class

Fasteners should be replaced with the same or higher property class. If higher property class fasteners used, these should only be tightened to the strength of the original.

\* “Lubricated“ means coated with a lubricant such as engine oil, or fasteners with phosphosphate and oil coatings.

Make sure fasteners threads are clean and that you properly start thread engagement. This will prevent them from failing when tightening.

Tighten plastic insert or crimped steel-type lock nuts to approximately 50 percent of the dry torque shown in the chart, applied to the nut, not to the bolt head. Tighten toothed or serrated-type lock nuts to the full torque value.

\*\* “Dry“ means plain or zinc plated without any lubrication.



# 10.0. Technical Specifications

## 10.5. Chassis Number

Enter the respective product identification no. in the space provided below. Always quote this number when ordering spare parts or in case of warranty claims.

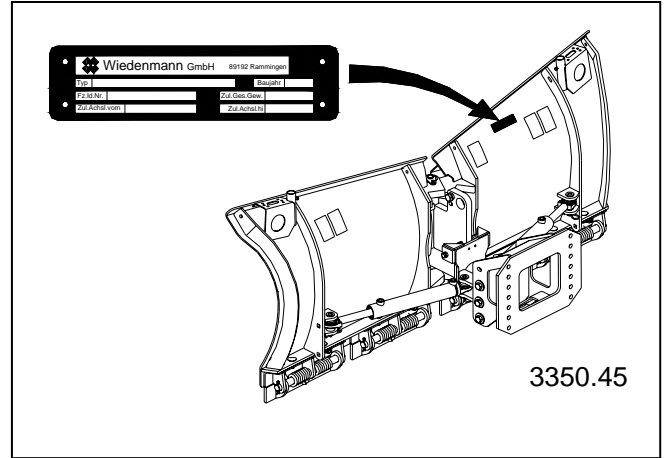

Product Id. number .....